

RCA

PRO8[®]

Video Camcorder Model Pro807 Owner's Manual

8



Product Registration	Inside Front Cover
Safety Precautions	1-3
Optional Accessories	4-7
• Accessory Order Form	5-6
Using an Optional Tripod	7
First-Time Operation	8-13
Remote Control	14-15
Powering Your Camcorder	16-19
RCA Video Cassettes	20
Special Features	
• Camera Edit	21
• Quick Review	21
• Flying Erase Head	21
• Earphone Jack	21
• <i>AUTO LOCK</i> Switch	21
• Tape Positioning	21
• Microphone.....	21
• Tally Light	21
Recording Features	
• Date and Time Display.....	22-23
• Electronic Viewfinder	23
• Displays in Viewfinder	24-25
• Power Zooming	25
• Focusing Your Camcorder	26
• Preset Program Modes.....	27
• Time Counter with Memory Stop.....	28
Recording and Traveling Tips	29
Care and Maintenance	30
Playback Features	
• Viewfinder Playback	31
• Playback on TV (or VCR) Using Antenna Connections	32-33
• Playback on TV (or VCR) Using <i>AUDIO/VIDEO IN</i> Jacks	34-35
Trouble Checks	36-37
Design Specifications	38
Limited Warranty	39
Index (Alphabetical)	40-41

Product Registration

Mail Your Registration Card Today

A *Product Registration Card* is packed with your camcorder. Please fill out the card and return it immediately.

Your prompt submission of this card confirms your right to the protection available under the terms and conditions of the warranty and also allows us to contact you should it ever become necessary.

With your card on file, we can also help you in the event of loss or theft by verifying your ownership.

If you did not receive a *Product Registration Card*, please contact your dealer.

Attach Sales Receipt Here and File For Future Reference

To obtain warranty parts and service, you must show your sales receipt (or other evidence of purchase) to your Authorized RCA Compact Camcorder Servicenter.

Tape or staple your sales receipt to this manual so you will have it handy should service ever be

needed. Do not mail your sales receipt to us. File it at home with your owner's manual for future reference.

Record Vital Information Here.

No other RCA camcorder has the same serial number as yours. You will find the serial number and model number on the bottom of your camcorder. Make sure both numbers are recorded below so that you will have them in case your camcorder is stolen or you need a complete description for identification.

Model No. Pro807

Serial No. _____

Purchase Date: _____

Purchased From: _____

IMPORTANT SAFETY INSTRUCTIONS

Important Safety Instructions for AC Adapter/Charger

Before using the AC adapter/charger, read all instructions and cautionary markings on

(1) AC adapter/charger, (2) battery, and
(3) product using battery.

Caution: To reduce risk of injury, charge only rechargeable batteries type AV608 or AV8MM.

Other types of batteries may burst causing personal injury and damage.

Do not expose the adapter/charger to moisture of any kind.

Use of an attachment not recommended or sold by the battery charger manufacturer may result in a risk of fire, electric shock, or injury to persons.

To reduce risk of damage to electric plug and cord, pull out the cord with the plug rather than the cord when disconnecting the adapter/charger from the wall outlet.

Make sure the cord is located so that it will not be stepped on, tripped over, or otherwise subjected to damage or stress.

Use of an improper extension cord could result in a risk of fire and electric shock. If an extension cord must be used, make sure that:

1. Pins on the plug of the extension cord are the same number, size, and shape as those of the plug on the adapter/charger.
2. Extension cord is properly wired and in good electrical condition, and
3. Wire size below is met:

Minimum AWG Size	Length of Extension Cord in Feet
18	Equal to or less than 100
16	Equal to or less than 150

Do not operate adapter/charger with a damaged cord or plug. Replace it immediately.

Do not operate adapter/charger if it has received a sharp blow, been dropped, or otherwise damaged in any way. Take it to a qualified serviceman.

Do not disassemble charger. Take it to an Authorized RCA Compact Camcorder Servicenter when service or repair is required. Incorrect reassembly may result in a risk of electric shock.

To reduce risk of electric shock, unplug charger from outlet before attempting any maintenance or cleaning.

Be sure to save these operating instructions for future reference.

Safety Precautions

Your video camcorder's AC adapter/charger will operate on 100-240 volts AC, 50/60 Hz, and has a polarized plug. Because one blade of the plug is wider than the other, the plug fits in the wall socket only one way. Do not defeat the safety feature of this plug. If you need an extension, use a polarized cord.

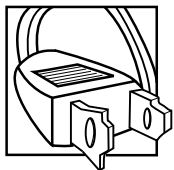

CAUTION: To prevent electric shock, match wide blade of plug to wide slot, fully insert.

MISE EN GARDE: Pour prévenir les chocs électriques, introduire la lame la plus large de la fiche dans la borne correspondante de la prise et pousser jusqu'au fond.

CAUTION: To reduce the risk of electric shock, do not remove the cover or back. No user-serviceable parts are inside. If you spill liquid on the camcorder or AC adapter/charger, disconnect the AC adapter/charger's power cord to prevent possible fire or shock hazard and consult authorized service personnel. Moisture can damage internal parts. Refer all service to Authorized RCA Compact Camcorder Servicenter personnel only.

Caution: Maintain electrical safety. Powerline-operated equipment or accessories connected to this unit should bear the UL listing mark or CSA certification mark on the accessories themselves and should not have been modified so as to defeat the safety features. This will help avoid any potential hazard from electric shock or fire. If in doubt, contact qualified service personnel.

WARNING: To prevent fire or shock hazard, do not expose camcorder or AC adapter/charger to rain or moisture.

Caution: Avoid operating your camcorder immediately after moving it from a cold location to a warm location. Give the camcorder 1-1/2 to 2 hours to reach a stable temperature before inserting a video cassette. When moved from a cold area to a warm location, moisture may condense on the head drum inside the machine. This moisture could cause the tape to stick to the headwheel and damage the headwheel or tape.

CAUTION

RISK OF ELECTRIC SHOCK
DO NOT OPEN

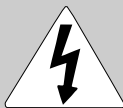

MISE EN GARDE

RISQUE DE CHOC ELECTRIQUE
NE PAS OUVRIR



The symbol of a lightning flash within a triangle is intended to alert the user to the presence of uninsulated "dangerous voltage" within the product's enclosure and which may be of sufficient magnitude to constitute a risk of electric shock.



An exclamation point within a triangle is intended to alert the user to the presence of important operating and maintenance (service) instructions in the literature accompanying the product.

FCC Warning: Any unauthorized changes or modifications to this equipment may void the user's authority to operate.

Caution: The unauthorized recording of television programs and other materials may infringe the rights of others.

IMPORTANT SAFEGUARDS

In addition to the careful attention devoted to quality standards in the manufacture of your video product, safety is a major factor in the design of every instrument. However, safety is your responsibility too.

These pages list important information that will help to assure your enjoyment and proper use of a camcorder, adapter/charger and accessory equipment. Please read them carefully before operating your video products.

Installation

- 1. Read and Follow Instructions**—All the safety and operating instructions should be read before the video product is operated. Follow all operating instructions.
- 2. Retain Instructions**—The safety and operating instructions should be retained for future reference.
- 3. Heed Warnings**—Comply with all warnings on the video product and in the operating instructions.
- 4. Polarization**—This video product is equipped with a polarized alternating-current line plug (a plug having one blade wider than the other). This plug will fit into the power outlet only one way. This is a safety feature. If you are unable to insert the plug fully into the outlet, try reversing the plug. If the plug still fails to fit, contact your electrician to replace your obsolete outlet. To prevent electric shock, do not use this polarized plug with an extension cord, receptacle, or other outlet unless the blades can be fully inserted without blade exposure. If you need an extension cord, use one with a polarized plug.
- 5. Power Sources**—This video product should be operated only from the type of power source indicated on the marking label. If you are not sure of the type of power supply to your home, consult your video dealer or local power company. For video products intended to operate from battery power, or other sources, refer to the operating instructions.
- 6. Overloading**—Do not overload wall outlets or extension cords as this can result in a risk of fire or electric shock. Overloaded AC outlets, extension cords, frayed power cords, damaged or cracked wire insulation, and broken plugs are dangerous. They may result in a shock or fire hazard. Periodically examine the cord, and if its appearance indicates damage or deteriorated insulation, have it replaced by your service technician.
- 7. Power-Cord Protection**—Power-supply cords should be routed so that they are not likely to be walked on or pinched by items placed upon or

against them, paying particular attention to cords at plugs, convenience receptacles, and the point where they exit from the video product.

- 8. Ventilation**—Slots and openings in the video products are provided for ventilation to ensure reliable operation of the video product and to protect them from overheating. These openings must not be blocked or covered. The openings should never be blocked by placing the video product on a bed, sofa, rug, or other similar surface. This video product should never be placed near or over a radiator or heat register. This video product should not be placed in a built-in installation such as a bookcase or rack unless proper ventilation is provided or the video product manufacturer's instructions have been followed.
- 9. Attachments**—Do not use attachments unless recommended by the video product manufacturer as they may cause hazards.

Caution: Maintain electrical safety.

Powerline operated equipment or accessories connected to this unit should bear the UL listing mark or CSA certification mark on the accessory itself and should not be modified so as to defeat the safety features. This will help avoid any potential hazard from electrical shock or fire. If in doubt, contact qualified service personnel.

- 10. Water and Moisture**—Do not use this video product near water—for example, near a bath tub, wash bowl, kitchen sink or laundry tub, in a wet basement, or near a swimming pool and the like.
- 11. Accessories**—Do not place this video product on an unstable cart, stand, tripod, bracket, or table. The video product may fall, causing serious injury to a child or adult as well as serious damage to the video product. Use this video product only with a cart, stand, tripod, bracket, or table recommended by the manufacturer or sold with the video product. Any mounting of the product should follow the manufacturer's instructions and use a mounting accessory recommended by the manufacturer.
- 11A** A video product and cart combination should be moved with care. Quick stops, excessive force, and uneven surfaces may cause the video product and cart combination to overturn.



IMPORTANT SAFEGUARDS (continued)

- 12. Outdoor Antenna Grounding**—If an outside antenna or cable system is connected to the video product, be sure the antenna or cable system is grounded so as to provide some protection against voltage surges and built-up static charges. Section 810 of the National Electrical Code, ANSI/NFPA No. 70-1984 (Section 54 of Canadian Electrical Code, Part 1) provides information with respect to proper grounding of the mast and supporting structure, grounding of the lead-in wire to an antenna-discharge unit, size of grounding conductors, location of antenna-discharge unit, connection to grounding electrodes, and requirements for the grounding electrode. See example below.

Example of Antenna Grounding

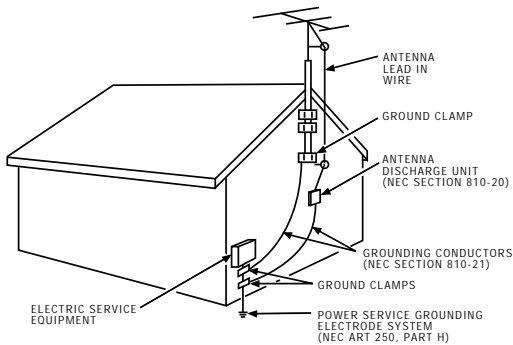

- 13. Power Lines**—An outside antenna system should not be located in the vicinity of overhead power lines, other electric light or power circuits, or where it can fall into such power lines or circuits. When installing an outside antenna system, extreme care should be taken to keep from touching or approaching such power lines or circuits as contact with them might be fatal. Installing an outdoor antenna can be hazardous and should be left to a professional antenna installer.

Use

- 14. Cleaning**—Unplug this video product from the wall outlet before cleaning. Do not use liquid cleaners or aerosol cleaners. Use a damp cloth for cleaning.
- 15. Object and Liquid Entry**—Never push objects of any kind into this video product through openings as they may touch dangerous voltage points or “short-out” parts that could result in a fire or electric shock. Never spill liquid of any kind on the video product.

- 16. Lightning**—For added protection for this video product during a lightning storm, or when it is left unattended and unused for long periods of time, unplug it from the wall outlet and disconnect the antenna or cable system. This will prevent damage to the video product due to lightning and power line surges.

Service

- 17. Servicing**—Do not attempt to service this video product yourself as opening or removing covers may expose you to dangerous voltage or other hazards. Refer all servicing to qualified service personnel.
- 18. Conditions Requiring Service**—Unplug this video product from the wall outlet and refer servicing to qualified service personnel under the following conditions.

- When the power-supply cord or plug is damaged.
- If liquid has been spilled, or objects have fallen into the video product.
- If the video product has been exposed to rain or water.
- If the video product does not operate normally by following the operating instructions. Adjust only those controls that are covered by the operating instructions. Improper adjustment of other controls may result in damage and will often require extensive work by a qualified technician to restore the video product to its normal operation.
- If the video product has been dropped or the case has been damaged.
- When the video product exhibits a distinct change in performance—this indicates a need for service.

- 19. Replacement Parts**—When replacement parts are required, have the service technician verify that the replacements he uses have the same safety characteristics as the original parts. Use of replacements specified by the video product manufacturer can prevent fire, electric shock, or other hazards.

- 20. Safety Check**—Upon completion of any service or repairs to this video product, ask the service technician to perform safety checks recommended by the manufacturer to determine that the video product is in safe operating condition.

Optional Accessories

We invite you to take a look at some great ideas for sparking creativity and adding to the fun of using your 8mm camcorder. These pages have a selection of accessories to help make your memorable moments look and sound even better.

These accessories are designed to make the process of recording and watching your videos more enjoyable.

To order accessories, contact your local Dealer.

If a dealer is not nearby, all accessories are available through toll-free ordering or by using the order form on page 5.

AC025A Soft Carrying Case

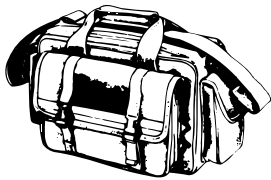

fabric lined with soft non-abrasive material and generous padding. Has three outside pockets with storage for lens filters, adapters, batteries, and tapes.

Custom compact soft case designed especially to provide protection and utility for your RCA 8mm camcorder and most accessories. Rugged

DCC05 DC Car Cord Adapter/Charger

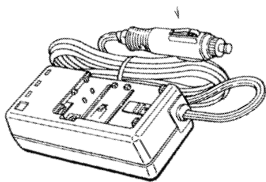

directly into the vehicle's cigarette lighter socket. It will also charge the AV608 battery supplied with the camcorder or the AV8MM long play battery. The DCC05 is specially designed to convert power from a 24-volt or 12-volt battery to a 6-volt output.

This DC car cord adapter/charger enables you to operate your camcorder from your car, truck, or RV by plugging the car cord

Caution: Do not use any other RCA car cord with this camcorder. It may damage the camcorder.

Rechargeable Batteries

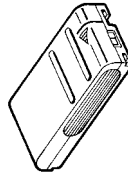

AV608

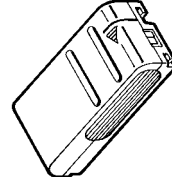

AV8MM

These rechargeable nickel-cadmium batteries are specifically designed for long life.

The AV608 can power your camcorder up to one hour, and the AV8MM up to two hours (depending on how much you use zoom and pause). Both can be recharged with the AC adapter/charger that came with your camcorder. Initial charging and recharging takes approximately one hour for the AV608 or two hours for the AV8MM.

Audio/Video Cables

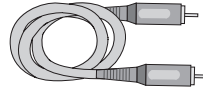

These cables are shielded for connecting *AUDIO* and *VIDEO* jacks. They have RCA-type phono plugs on each end.

AH069G (3-ft)

AH070G (5-ft)

Monaural VCR Dubbing Cable

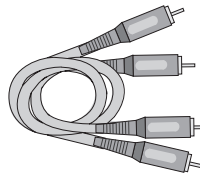

This is a double cable that lets you connect the *AUDIO* and *VIDEO* jacks of monaural components. It can be used to connect your camcorder to a TV monitor (or VCR). The cable is color coded and shielded with RCA-type phono plugs on each end.

AH075G (6-ft)

193983 Cable Transformer

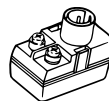

193983

The 193983 is used to connect a standard 300-ohm antenna twin-lead to a standard round 75-ohm connector on the RF output adapter.

All specifications and descriptions of accessories are subject to change without notice.

Optional Accessories Accessory Order Form

VCC1000 Video Color Control Center

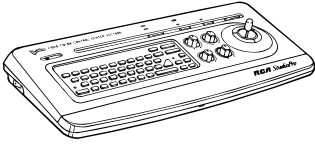

The VCC1000 is actually two accessories in one. The color control center allows you to adjust the color intensity, tint, white balance, and sharpness of tapes being dubbed. This is especially helpful when the original tape was produced in poor lighting conditions or poor color settings. The second feature, the character generator, lets you create titles that can be recorded on your tapes. This lets you add a professional and/or personal touch to your home videos.

VDC88 Color Enhancement Light

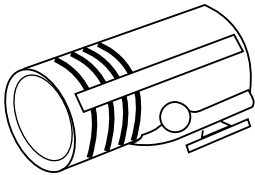

This ultra compact 15-watt video light is cordless, light in weight, and includes a rechargeable battery. It mounts on the top of the camcorder and fits on a standard accessory shoe. The VDC88 provides excellent soft, lush fill light. The VDC88 uses one 15-watt (VDC090) replacement bulb. The rechargeable battery BP1000 can be charged with the VDC085 battery charger.

Detach Here



Order Form for Pro807

Description	Part No.	Price	Qty.	Total
Soft Camcorder Case	AC025A	\$ 59.95		
Super Lightweight Tripod	AC035	\$ 69.95		
Gold-Tipped Audio/Video Cable (3-ft.)	AH069G	\$ 5.99		
Gold-Tipped Audio/Video Cable (5-ft.)	AH070G	\$ 7.99		
Gold-Tipped Dubbing Cable (6-ft.)	AH075G	\$ 10.99		
Rechargeable Battery	AV608	\$ 49.95		
Rechargeable Battery	AV8MM	\$ 59.95		
RF Output Adapter	CRF800	\$ 49.95		
AC Adapter/Charger	CPS800	\$189.95		
DC Car Cord Adapter/Charger	DCC05	\$169.95		
DC Cable for Adapter/Charger	DCC100	\$ 14.95		
Video Control Center	VCC1000	\$349.90		
Color Enhancement Light	VDC88	\$ 79.95		

Replacement Bulb (15 watt) for VDC88	VDC090	\$ 12.95		

Extra Battery for VDC88	BP1000	\$ 29.95		

Charger for BP1000	VDC085	\$ 18.95		

Replacement Remote Control	211026	\$ 49.95		

RF Connecting Cable	213003	\$ 11.95		

Shoulder Strap	213004	\$ 13.95		

Prices are subject to change without notice.

Total Merchandise (\$10 Minimum Order) \$ _____

Sales Tax \$ _____

We are required by law to collect the appropriate sales tax for each individual state, county, and locality to which the merchandise is being sent.

Shipping, Handling, and Insurance \$ 5.00

Total Amount Enclosed \$ _____

Use VISA or MasterCard preferably. Money order or check must be in U.S. currency only. No COD or CASH.

- All accessories are subject to availability.
- Where applicable, we will ship a superseding model.

Please complete other side also

Accessory Order Form (continued)

Charge your order on your VISA
or MasterCard by
filling in below

USE YOUR CREDIT CARD

IMPORTANT: Copy complete account number
from your VISA card



My card expires:

IMPORTANT: Copy complete account number
from your MasterCard



Copy Number
above your
name on
MasterCard

My card
expires:

AUTHORIZED SIGNATURE

Prices are subject to change without notice.

PLEASE

Print or type your name and
address clearly. This will be your
mailing label.

A complete and correct order will
save you days of waiting.

Name: _____

Street: _____

_____ Apt: _____

City: _____

State: _____ Zip: _____

Please make sure that both sides of this form have
been filled out completely.

- Allow 8 weeks for deliver.
- All accessories are subject to availability.
- Where applicable, we will ship a superseding model.

**To order accessories, contact your
local Dealer.**

If a dealer is not nearby, you can also
follow the directions below to order by
telephone or direct-by-mail.

United States Orders

To place your order by phone, have your
Visa or MasterCard ready and call the
toll-free number listed below between
8AM and 8PM Eastern Standard Time.

**Use this number only to place an
order for accessory items listed on this
order form.**

1 - 800 - 338 - 0376

Most times your order will be shipped
UPS within 72 hours of receipt. If ever
it is not possible to ship within 30 days,
we will notify you with an update on
your order and an option to cancel.

To place your order by mail, detach and
mail the completed order form with
credit card information, money order, or
check in U.S. currency (made payable to
Thomson Consumer Electronics, Inc.) to
the following address:

RCA Video Accessories
PO Box 8419
Ronks, PA 17573

**For more information on these
accessories (or current prices), write
to the following address:**

Video Accessories Customer Service
Thomson Consumer Electronics, Inc.
Distributor & Special Products
2000 Clements Bridge Rd
Deptford, NJ 08096-2088

Canadian Orders

For Canada inquiries, please call one of
these toll-free numbers for information
about accessories:

English: 1 - 800 - 668 - 5518
French: 1 - 800 - 668 - 5507

International Orders

This offer is valid only in the 50 United
States. For international orders, please
send your request for a price quotation
(not an order) to:

International Customer Service
Thomson Consumer Electronics, Inc.
Distributor & Special Products
2000 Clements Bridge Rd
Deptford, NJ USA 08096-2088

Detach Here

Optional Tripod

AC035 Super Lightweight Tripod

This tripod's fluid-effect head provides smooth camera pan and tilt. The quick-release mount makes it easy to attach or remove the camcorder. The grooved, tubular 3-section leg design folds down to 23-1/2" when not in use and weighs only 3-1/2 lbs. Rubber feet allow for sure footing.

Using an Optional Tripod

Mounting the camcorder on a tripod, such as AC035 will keep the camcorder steady and produce excellent video results.

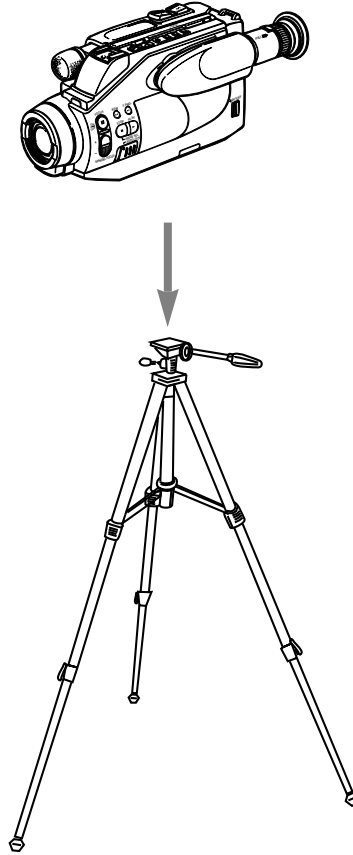

Caution: Before using a tripod, make sure it is stable enough to hold the camcorder without falling over.

When attaching your camcorder to a tripod, be careful not to force the tripod screw into the camcorder's tripod mounting hole.

The tripod screw should not protrude into the camcorder more than approximately three-eighth (3/8) inch. Forcing the screw could damage the mounting hole on the bottom of the camcorder.

First-Time Operation

Thank you for choosing an RCA camcorder.

You have selected a precision-engineered camcorder designed to give you years of performance and enjoyment.

Although your camcorder is very simple to use, it is important that you read and carefully follow the instructions in this manual until you are completely familiar with the proper operating procedures.

1. Unpack the camcorder and accessories.

Make sure you remove all the accessories and information papers that came packed with the camcorder.

- Save the packing materials and box in case you ever need to ship or store your camcorder.

If you should experience a problem, always refer first to "Trouble Checks" on pages 36-37. Many times a simple solution is all that is needed, and it could save you a costly service call. If your camcorder should require service during the warranty period, refer to page 39 for a description of what we will do and instructions on how to request service.

- The items shown below are packed with your camcorder. If any of the items are missing or appear damaged, contact your RCA dealer immediately.

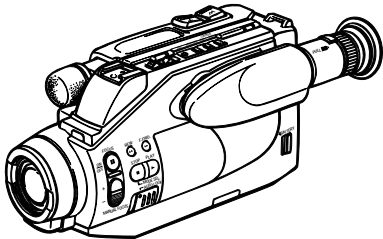

Camcorder: Model Pro807

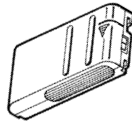

Rechargeable
6-Volt Battery
Stock No. AV608

WARNING:
NICKEL
CADMIUM
BATTERY
MUST BE
DISPOSED OF
PROPERLY.

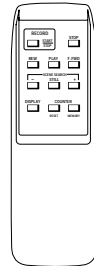

Remote Control
Stock No. 211026



Remote
Control
Batteries
(size "AA"
1.5 volt)

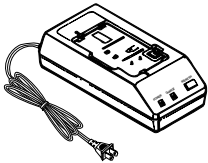

AC Adapter/Charger
Stock No. CPS800

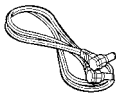

DC Connecting Cord
Stock No. DCC100

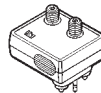

RF Output Adapter
Stock No. CRF800

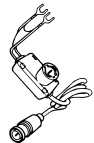

RF Connecting Cable
Stock No. 213003



Shoulder Strap
Stock No. 213004



Clock Battery:
3-Volt Micro
Lithium Cell (such
as Maxell No.
CR2025 available
from most local
drug stores and
camera shops)

Caution: Lithium battery. Must be disposed of properly. Never handle punctured or leaking batteries. May cause burns or personal injury. Can cause death or injury if swallowed. Keep out of hands of children. If swallowed, consult a physician immediately for emergency treatment.

First-Time Operation (continued)

2. Attach a power supply to the camcorder.

Attach a power supply to the camcorder—either the adapter/charger or charged battery.

Adapter/Charger

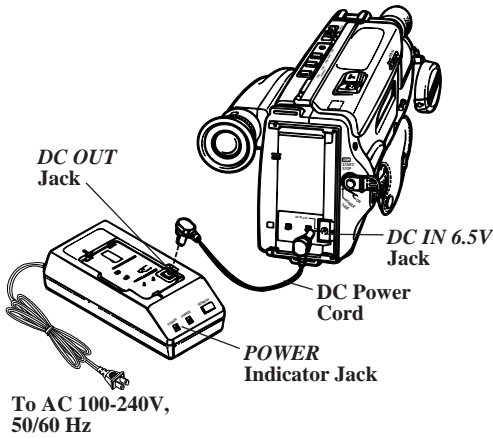

Connect one end of the DC power cord into the *DC OUT* jack on the adapter/charger. Plug the other end of the DC power cord into the *DC IN 6.5V* jack on the back of the camcorder. Plug the adapter/charger's plug into an operating outlet. The *POWER* indicator on the adapter/charger will light. *Details are on page 16.*

Charged Battery*

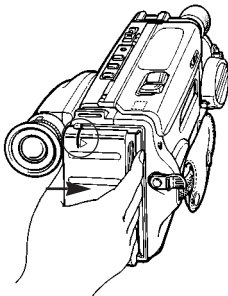

Attach charged battery to camcorder.

Make sure the camcorder's *POWER* switch is in the *OFF* position. Match the line on the battery to the line on the camcorder. Hold the battery flush against the camcorder and slide it in the direction of the arrow until a click is heard. *Details are on page 17.*

*The battery must be charged before it can be used the first time.

3. Remove the lens cap and attach it to the lens cap holder on the camcorder.

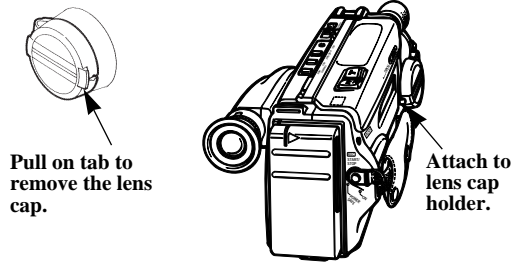

Pull on the tab on the side of the lens cap to remove it. Then pull it straight, rotate it down, and attach it to the lens cap holder on the side of the camcorder.

4. Attach the shoulder strap.

1. Unfasten one end of the shoulder strap from the buckle. Make sure you leave the buckle on the strap.



2. Thread one end of the shoulder strap through one of the shoulder strap rings (located on the top and bottom of the camcorder).

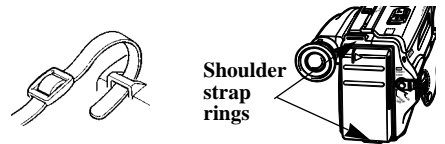

3. Thread the strap back into the buckle. Pull on the strap and make sure it is securely fastened before using the shoulder strap to support the camcorder.

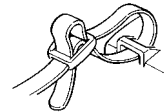

4. Repeat steps 1-3 for the other end of the shoulder strap.

(continued on next page)

First-Time Operation (continued)

5. Adjust the hand strap.

Adjust the hand strap so it is snug around your hand when you place your thumb on the thumb trigger and your middle and index fingers on the power zoom buttons.

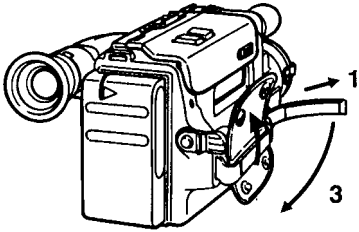

1. Unsnap the flap and open the adjustment strap
2. Put your hand in the hand strap.
3. Pull the adjustment strap to tighten.
4. Snap the flap closed.

6. Turn on the camcorder.

Because your camcorder is both a camera and a VCR, it performs two completely separate groups of functions. The position of the **POWER (CAM (camera) /OFF/PLAY)** switch tells the camcorder whether you want to record (**CAM**), play back tapes (**PLAY**), or turn off the camcorder's power (**OFF**). Some of the controls operate differently depending on the position of the **POWER** switch.

- Press and hold the small button on the **POWER** switch while sliding it to the **CAM** position.

7. Place the **ON/POWER SAVE** lever in the **ON** position.

The camcorder also has an **ON/POWER SAVE** lever to conserve battery power when recording.

- During recording, place the **ON/POWER SAVE** lever in the **ON** position. The camcorder will not record unless this lever is in the **ON** position.
- Place the **ON/POWER SAVE** lever in the **POWER SAVE** position during recording breaks. The camcorder will enter the "standby mode".

Important Note: The dew indicator  will appear in the electronic viewfinder when there is excessive moisture in the camcorder. Remove the cassette from the camcorder and let it dry naturally.

8. Insert a cassette in the camcorder.

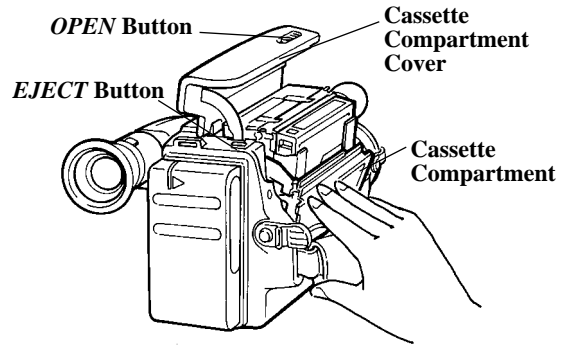

1. Slide the **OPEN** button and completely open the cassette compartment cover.
2. Press the **EJECT** button to open the cassette compartment.
3. Insert a cassette only one way with the record-protect (safety) tab facing up and the tape window facing out.
4. Gently press on the side of the cassette compartment where it is labeled **PUSH** (as shown above) until it locks into place.
5. After the cassette compartment is fully retracted, close the cassette compartment cover.

Note: If the cassette you load into the cassette compartment has been rewound in a different unit, the cassette compartment may open again. Make sure the cassette compartment is completely retracted before closing the cassette compartment cover.

9. Set **AUTO LOCK** switch in the **AUTO LOCK** position.

10. Pull out the electronic viewfinder and adjust the eyepiece focus control for your vision.

- Pull the electronic viewfinder out into the operating position.
- If the image in the viewfinder is blurry, adjust the eyepiece focus control for your vision.
Details are on page 23.

First-Time Operation (continued)

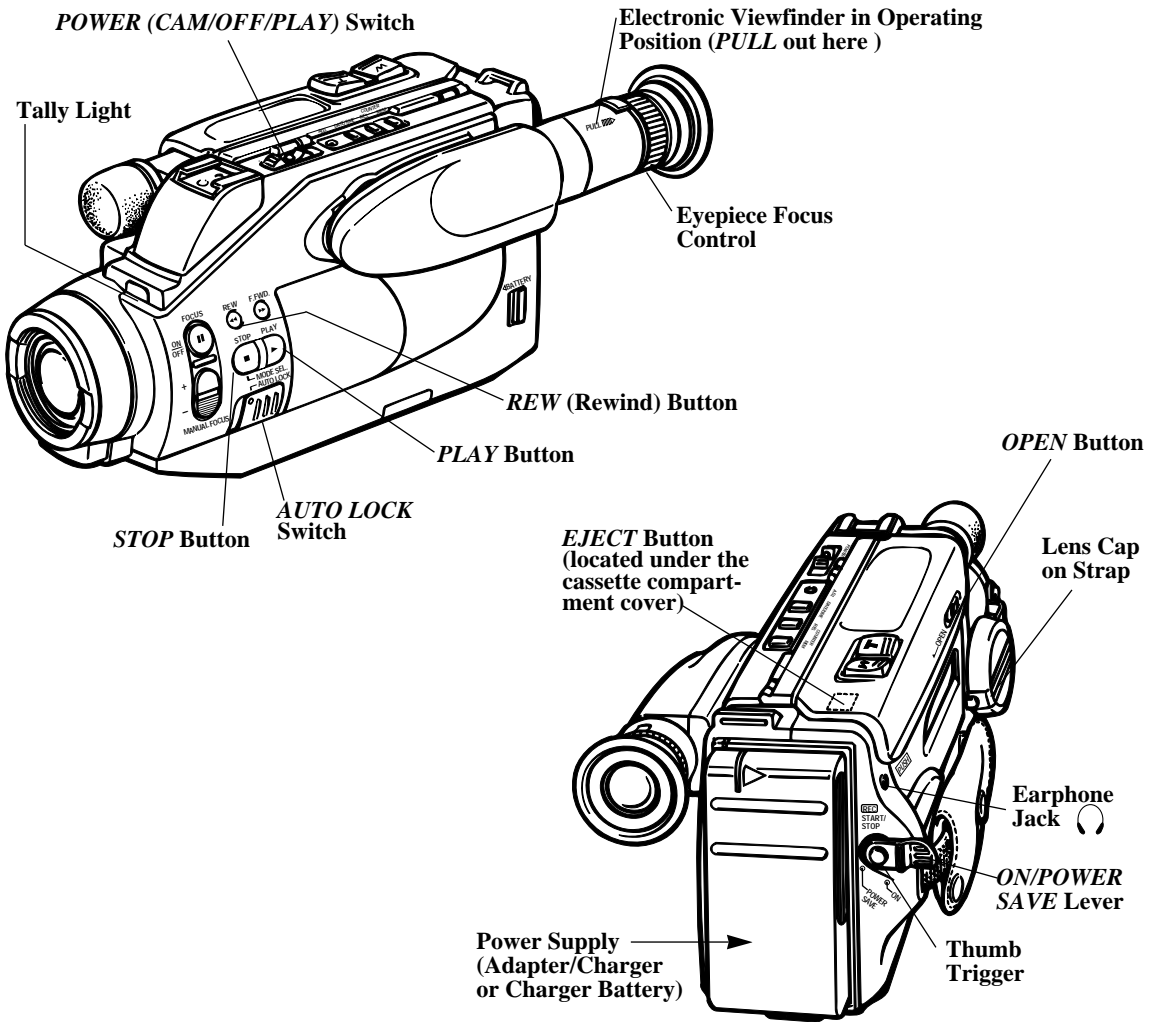

11. Start and stop recording.

Start and stop recording by pressing and releasing the thumb trigger. You do not have to hold the thumb trigger to record. The *REC* indicator appears in the viewfinder when the camcorder is recording.

Notes: The tally light flashes during record-pause and goes off when the camcorder is recording or the, *ON/POWER SAVE* lever is placed in the *POWER SAVE* position.

If you do not record within five minutes, the camcorder will automatically shut off to prevent excessive tape wear. To resume recording press the thumb trigger twice.

Any material recorded on the tape will automatically be erased if you record over it.

To monitor the audio being recorded, attach an optional earphone to the earphone jack.

12. Play back what you have recorded.

- Press the thumb trigger to stop recording.
- Place the *POWER* switch in the *PLAY* position.
- Press the *REW* (rewind) button to rewind the tape.
- Then press the *PLAY* button to play back the tape in the electronic viewfinder.
- Press the *STOP* button when you are finished playing back the tape.
- *Details on viewfinder playback are on page 31.*

First-Time Operation (continued)

13. Review all of the camcorder's operating controls.

The page number(s) where detailed information on each control can be found are listed for your convenience.

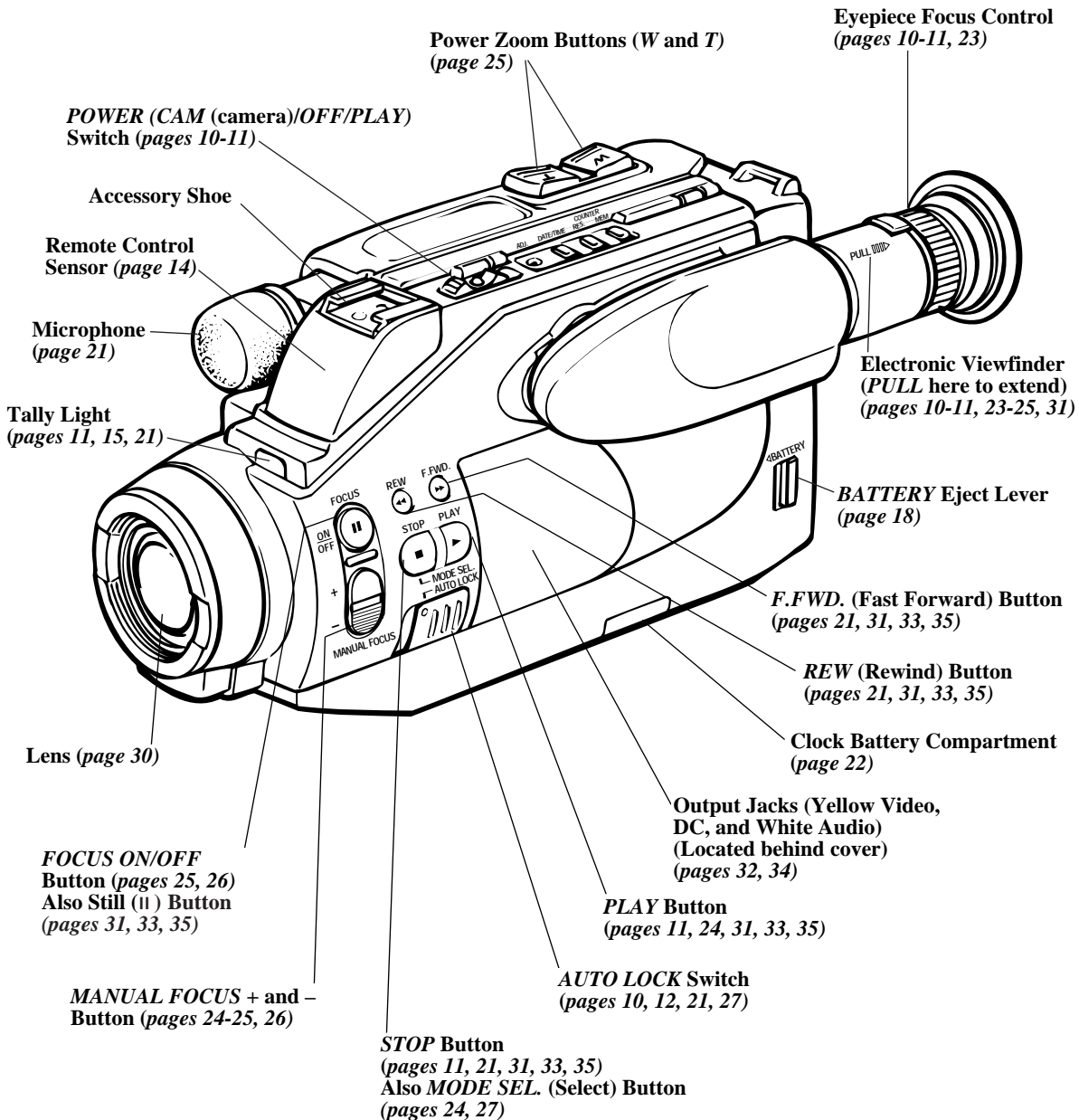

First-Time Operation (continued)

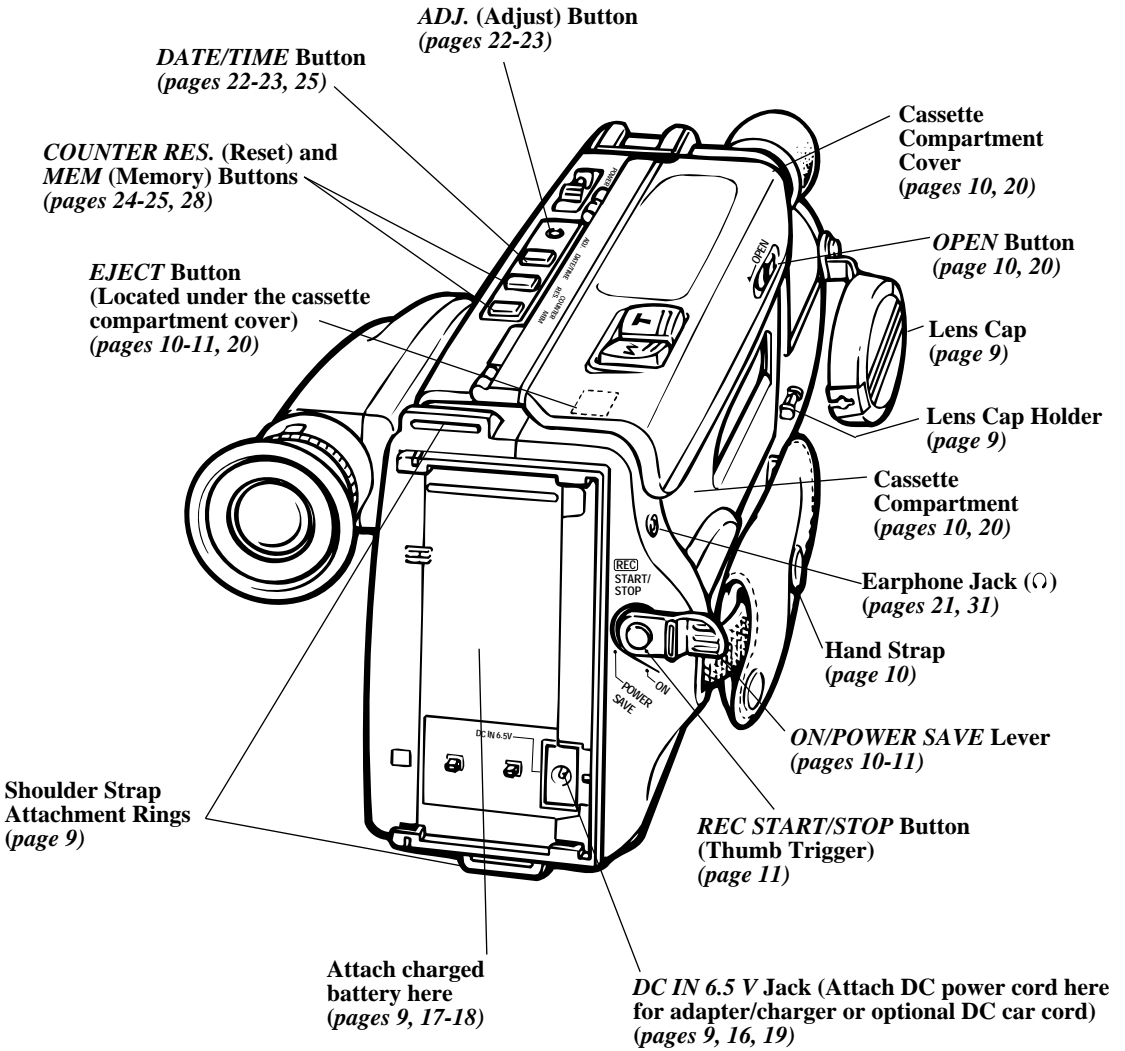

Remote Control

Battery Installation

The batteries supplied with your remote control are packed separately. Install them as follows.

1. Turn the remote control over and slide the battery compartment cover off.
2. Insert the batteries so that their positive (+) ends contact the positive terminals in the battery compartment.
3. Replace the cover.

Notes: Never place anything heavy on top of the remote control or lay it upside-down. This may accidentally depress the buttons for a long time and discharge the batteries.

Replace the batteries when the camcorder fails to respond to the remote control. Remove the batteries from the remote control if it will not be used for a month or more. This will prevent possible damage from battery leakage. If leakage occurs, wipe up the liquid inside the compartment and replace the batteries with new ones.

Do not use new and used batteries together.

Different brands and types of batteries have different voltages. Do not use different brands or types of batteries together.

Remote Control Sensor

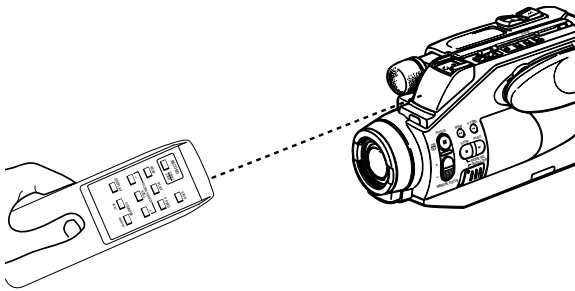

The remote control operates the camcorder by infrared light, so it is protected from electrical and sound interference. However, the remote control must be aimed directly at the camcorder's remote control sensor. There cannot be any obstructions between them. The remote control should operate up to approximately 16 feet from the camcorder. Replace the remote control batteries if the operation distance decreases.

Note: The camcorder may not respond to the remote control if the camcorder's remote control sensor is exposed to direct sunlight or strong artificial light.

Location and Function of Remote Control Buttons

A brief description of the functions of the remote control buttons is given here. Most of the remote control buttons perform the same function as the corresponding controls on your camcorder. You can use whichever are more convenient at the time.

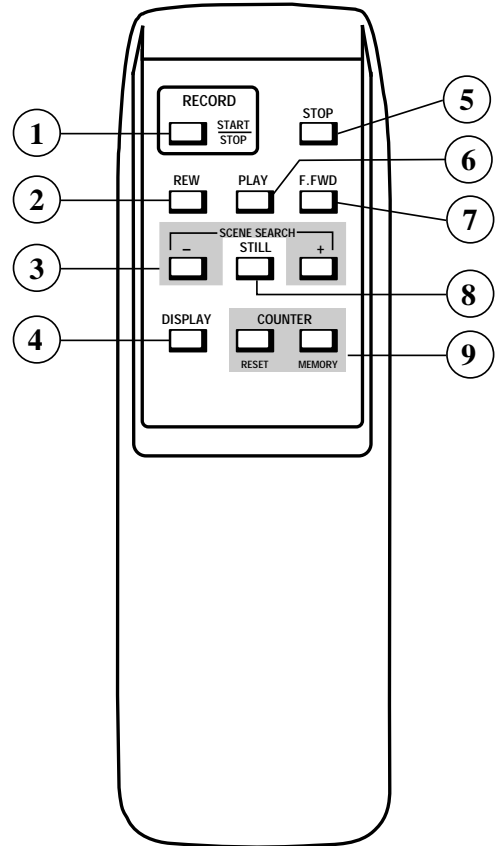

Note: An RCA VCR that is set to respond to the VCR 2 button on the VCR's remote control may respond to this remote control when it is used to operate the camcorder.

Remote Control (continued)

Location and Function of the Remote Control Buttons (continued)

① **RECORD START/STOP Button (Same as Thumb Trigger on Camcorder)**

Press and release the *RECORD START/STOP* button when the *POWER* switch is in the *CAM* (camera) position to start and stop recording. The tally light will light continuously during recording when you start recording using this button on the remote control.

Notes: The camcorder's *ON/POWER SAVE* lever must be in the *ON* position for the camcorder to record.

If the camcorder is left in the record-pause mode (*POWER* switch in the *CAM* position) for more than five minutes, the camcorder's power will turn off. To begin recording again, press the *RECORD START/STOP* button twice.

② **REW (Rewind) Button**

- Press the *REW* button when the camcorder's *POWER* switch is in the *PLAY* position to rewind the tape.
- During playback or rewind (*POWER* switch in the *PLAY* position), press and hold the *REW* button to visually search the tape in reverse. Release the *REW* button to return to normal playback or rewind.

③ **SCENE SEARCH + and – Buttons**

When the camcorder's *POWER* switch is in the *CAM* position (record-pause mode), press one of the *SCENE SEARCH* buttons to visually search the tape.

- Press and hold the *SCENE SEARCH +* button to visually search forward on the tape. Release the button to return to record-pause.
- Press and hold the *SCENE SEARCH –* button to visually search the tape in reverse. Release the button to return to record-pause.

④ **DISPLAY Button**

Press the *DISPLAY* button when the camcorder is connected to a TV to see the viewfinder's displays on the TV screen. Press the *DISPLAY* button again to remove them. *Details on connecting a TV are on pages 32-35.*

⑤ **STOP Button**

- Press this button when the camcorder's *POWER* switch is in the *PLAY* position to stop playback, rewind, or fast forwarding.
- The *STOP* button has no effect when the camcorder's *POWER* switch is in the *CAM* position. To stop recording, press the *RECORD START/STOP* button ①.

⑥ **PLAY Button**

Press the *PLAY* button when the camcorder's *POWER* switch is in the *PLAY* position to begin playback.

⑦ **F.FWD (Fast Forward) Button**

- Press the *F.FWD* button when the camcorder's *POWER* switch is in the *PLAY* position to fast forward the tape.
- During playback or fast-forward operation (*POWER* switch in the *PLAY* position), press and hold the *F.FWD* button to visually search forward on the tape. Release the *F.FWD* button to return to normal playback or fast-forward operation.

⑧ **STILL Button**

- During playback, press the *STILL* button to produce a stop-action picture. Press the *STILL* button again to return to normal playback.
- This button has the same function as the still (II) button on the camcorder.
Note: Some picture noise is normal during stop-action playback.

⑨ **COUNTER (RESET and MEMORY) Buttons**

These buttons have the same function as the *COUNTER RES.* and *COUNTER MEM* buttons on the camcorder. *Details are on page 28.*

Powering Your Camcorder

Using the Adapter/Charger to Power Your Camcorder

The adapter/charger attaches to the camcorder and lets you power your camcorder directly from standard household power. The adapter/charger operates on 100-240 volts, 50/60 Hz, so it can be used virtually anywhere in the world to power the camcorder or recharge the battery. You may need a plug adapter in some countries. Consult your RCA dealer. Be sure to purchase the plug adapter before traveling. The adapter can be hard to find in foreign countries.

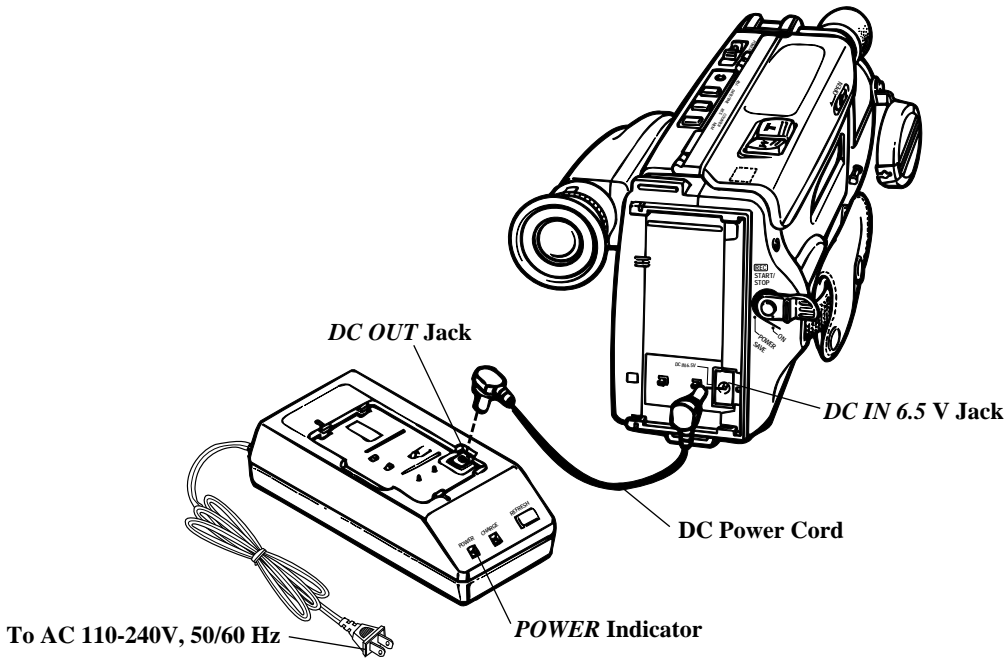

To Attach the Adapter/Charger

1. Plug one end of the DC power cord into the *DC OUT* jack on the adapter/charger.
2. Plug the other end of the DC power cord into the *DC IN 6.5V* jack on the back of the camcorder.
3. Plug the adapter/charger's plug into the nearest AC outlet (100-240V, 50/60Hz).
4. If the adapter/charger is properly connected, its *POWER* indicator will light.

To Remove the Adapter/Charger

1. Unplug the adapter/charger from the wall outlet.
2. Disconnect the DC power cord from the camcorder and the adapter/charger.

Using an optional plug adapter

An optional plug adapter may be required in some countries.

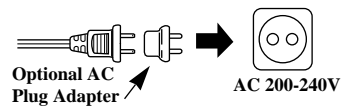

1. Plug the adapter/charger's plug into the AC plug adapter.
2. Plug the AC plug adapter into an AC outlet.

Powering Your Camcorder (continued)

Using the Battery to Power Your Camcorder

The battery must be charged before it can be used the first time. Initial charging will take approximately one hour. When fully charged, the battery should supply about 45-60 minutes of operating time (depending on how much you use zoom and pause, auto focus, and record-pause).

The adapter charger has a *REFRESH* button that allows you to completely discharge the battery. The nickel cadmium battery will provide longer operation time if it is “refreshed” before charging. Refreshing a battery will take approximately 3-1/2 hours. The operation time of the battery may decrease if the battery’s power has not been completely exhausted before it is recharged. Refresh a partially discharged battery before recharging it.

When using the battery to power the camcorder, place the *ON/POWER SAVE* lever in the *POWER SAVE* position during recording breaks to conserve the battery’s power. Place it back in the *ON* position when you are ready to resume recording.

Note: The small marker switch on the top of the battery is for use as a personal reminder to help you remember to recharge the battery. It has no other function.

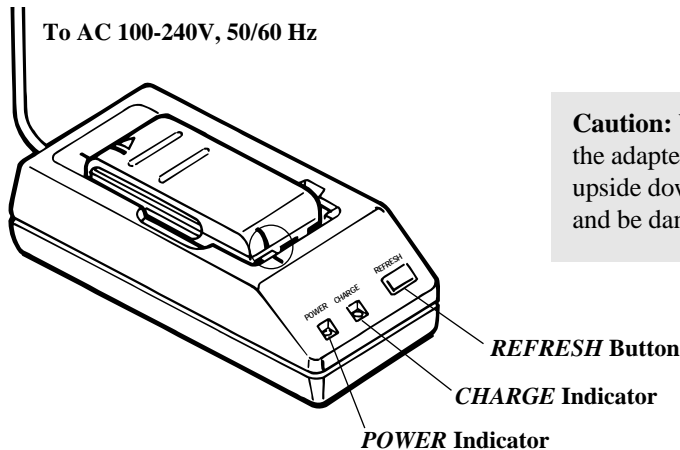
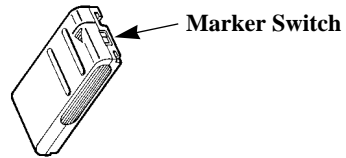

Caution: When a battery is attached to the adapter/ charger, do not turn them upside down. The battery may fall off and be damaged or cause injury.

Charging the Battery

If the DC cord is connected to the adapter/charger, remove its plug.

1. Plug the adapter/charger into the nearest AC outlet (100-240V, 50/60Hz). The *POWER* indicator will light.
2. Align the reference mark on the battery with the line on the adapter/charger.
3. Hold the battery flush against the adapter/charger and slide it in the direction of the arrow until it locks into place.
4. Press the *REFRESH* button to discharge the battery. After a few seconds the *CHARGE* indicator will slowly flash. The *CHARGE*

indicator will stop flashing after the battery has been discharged. Then, the *POWER* indicator will light, and the battery will automatically recharge.

Note: If the *CHARGE* indicator on the AC adapter/charger starts flashing rapidly, remove the battery from the adapter/charger. Try attaching the battery again. Make sure it is correctly attached.

5. Remove the charged battery by sliding it off the adapter/charger. Unplug the AC power cord from the AC outlet.
6. Attach the charged battery to the camcorder as shown on the next page.

Powering Your Camcorder (continued)

Attaching the Charged Battery to the Camcorder

If the DC cord is attached to the camcorder, remove it before attaching the battery.

1. Align the reference line on the battery with the line on the back of the camcorder.
2. Hold the battery flush against the camcorder and slide it in the direction of the arrow.
3. Slide the camcorder's *POWER* switch to the *CAM* position, and place the *ON/POWER SAVE* lever in the *ON* position.

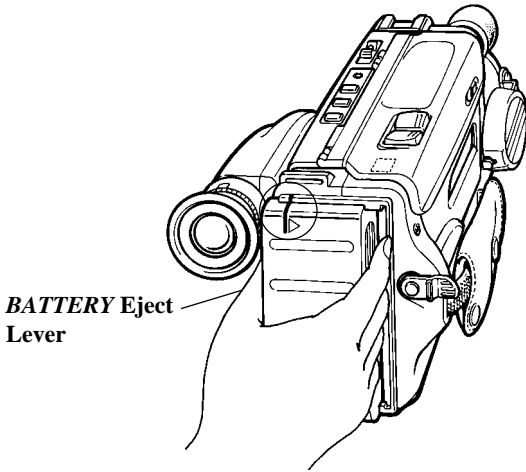

WARNING: NICKEL CADMIUM BATTERY MUST BE DISPOSED OF PROPERLY.

Removing the Battery From the Camcorder

Slide and hold the *BATTERY* eject lever on the camcorder while sliding the battery to the left and off the camcorder.

Battery Safety Precautions

Do not short the battery's terminals.

Do not attempt to disassemble or modify the battery. There are no user-serviceable parts inside.

Use the battery only with specified RCA adapter/chargers and camcorders.

Low Level Battery Warning

The battery warning indicator (⚡) will appear in the viewfinder when the battery power is low. Recharge the battery, or use the adapter/charger to power the camcorder.

Caution: When the battery reaches its empty level while you are using it, the camcorder will shut off. However, the battery should have enough reserve power to eject the cassette when you press the *EJECT* button. If the camcorder does not eject the cassette when you press the *EJECT* button, do not attempt to force the cassette compartment open. This will damage the camcorder. Power your camcorder with the adapter/charger, or recharge the battery before attempting to eject the cassette.

Proper Care and Storage of Your Battery

The battery will provide better service and longer performance if you charge it before use and store it at normal room temperature.

The nickel cadmium battery will provide better service if it is used until it reaches the empty level (camcorder automatically turns off) before recharging. Use the refresh feature if the battery is not completely discharged.

The battery should be charged at a temperature of 41°F-95°F (5°C-35°C) to prevent damage.

Do not operate the battery at temperatures below 14°F (-10°C) or above 95°F (35°C). The battery may be damaged if operated at temperatures above 122°F (50°C). Operation time will decrease at extremely low temperatures.

When the battery is used the first time, the recording time will be slightly shorter than normal. To receive full operation time from the battery, refresh and recharge the battery two or three times.

After repeated chargings and use, the operation time will gradually decrease. When operation time becomes too short to be useful, it is time to replace the battery.

Powering Your Camcorder (continued)

Using the Optional RCA DCC05 Car Cord Adapter/Charger

The optional RCA DCC05 DC car cord adapter/charger allows you to power your camcorder from the cigarette lighter socket of a car, truck, or RV. It converts 24- and 12-volts to a 6-volt output. The DCC05 can also charge the battery that came with your camcorder and the AV8MM (long play) battery.

Consult the installation and operating instructions enclosed with the DCC05 for complete operating instructions.

Cautions: The DCC05 is designed to be used only with vehicles having negative ground electrical systems.

Do not use any other RCA car cord with this camcorder. Other RCA car cords may damage your camcorder.

Using the RCA DCC05 Car Cord Adapter/Charger to Power the Camcorder

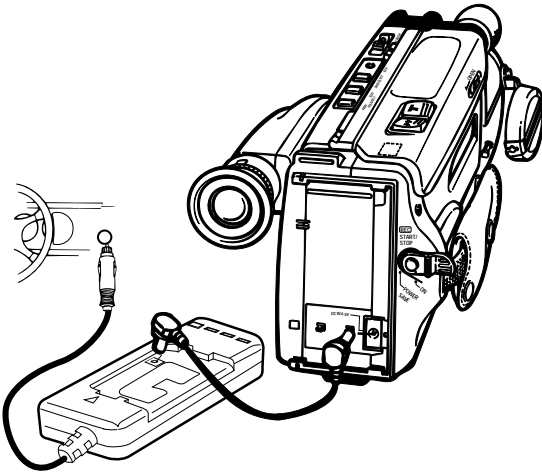

1. If the battery is attached to the camcorder or car cord adapter/charger, remove it.
2. Plug one end of the DC power cord into the *DC OUT* jack on the car cord adapter/charger and the other end into the *DC IN 6.5 V* jack on the back of the camcorder.
3. Insert the plug on the DCC05 into the vehicle's cigarette lighter socket. If the car cord is properly attached, the *POWER* indicator on the DCC05 will light.

Using the RCA DCC05 Car Cord Adapter/Charger to Charge the Battery

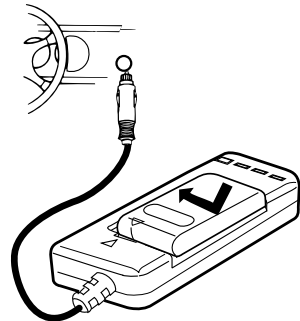

1. If the DC power cord is attached to the car cord adapter/charger, remove it.
2. Attach the battery to the car cord adapter/charger as shown.
3. Insert the plug on the DCC05 into the vehicle's cigarette lighter socket. If the car cord and battery are properly attached, the *POWER* and *CHARGE* indicators on the DCC05 will light.

Note: Use the *REFRESH* feature on the adapter/charger to maximize the life of your battery.

RCA Video Cassettes

We recommend that RCA cassettes be used with your camcorder. The tape in these cassettes is of high-quality formulation. It has been manufactured to our critical specifications for excellent performance. Use of tape not meeting these specifications could considerably reduce the performance of your camcorder.

Use of poor quality tapes or tapes that have been damaged or mishandled can contaminate the video heads, resulting in a snowy picture or no picture at all during playback. Because there is no control over the type of tape purchased or rented by consumers, head cleaning is not covered under warranty. It is considered normal maintenance.

Playing a new RCA tape for approximately 30 minutes will often satisfactorily clean the heads and improve your picture.

Erase Protection–Record-Protect (Safety) Tab

You can use your video cassettes over and over again. To erase a previous recording, just record over it.

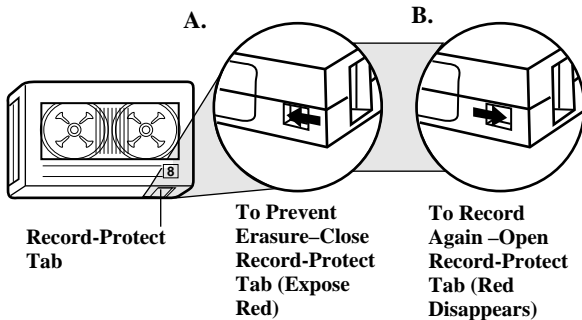

A. To prevent erasing a recording you want to keep, close the cassette's record-protect tab by sliding it in the direction of the arrow until the red area is completely visible.

B. To record again on the cassette, slide the record-protect tab open in the direction of the arrow until the red area disappears behind the cassette case.

Recording and Playback Speeds and Times

The camcorder records in standard speed (SP). The chart in the next column shows the maximum SP recording times for some popular 8mm cassettes.

The camcorder can play back tapes in standard speed (SP) or long play (LP) speed. The playback speed is automatically selected by the camcorder. The *LP* indicator appears in the electronic viewfinder when the camcorder is playing back a tape recorded in the LP speed.

Inserting and Removing Cassettes

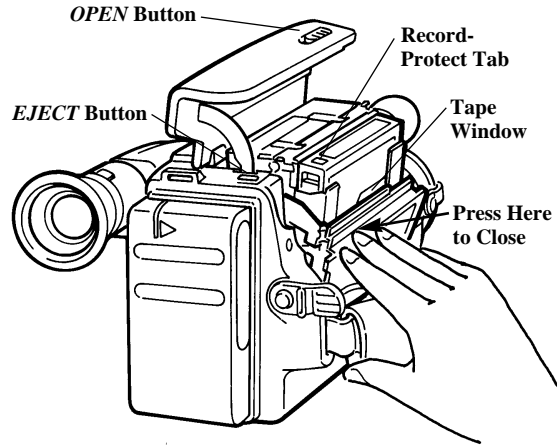

1. Attach a power supply to the camcorder.
2. Slide the *OPEN* button and completely open the cassette compartment cover.
3. Press the *EJECT* button to open the cassette compartment. Insert or remove the cassette.

Caution: Insert the cassette only one way with the record-protect tab facing up and the tape window facing out. The cassette should slide easily in the compartment. Do not force the cassette.

4. Close the cassette compartment door. Gently press on the area labeled *PUSH* as shown above.
5. After the cassette compartment is fully retracted, close the cassette compartment cover.

Cassette	Recording Time
P6-15	15 Minutes
P6-20	20 Minutes
P6-45	45 Minutes
P6-60	60 Minutes
P6-90	90 Minutes
P6-120	2 Hours
P6-150	2 1/2 Hours

Special Features

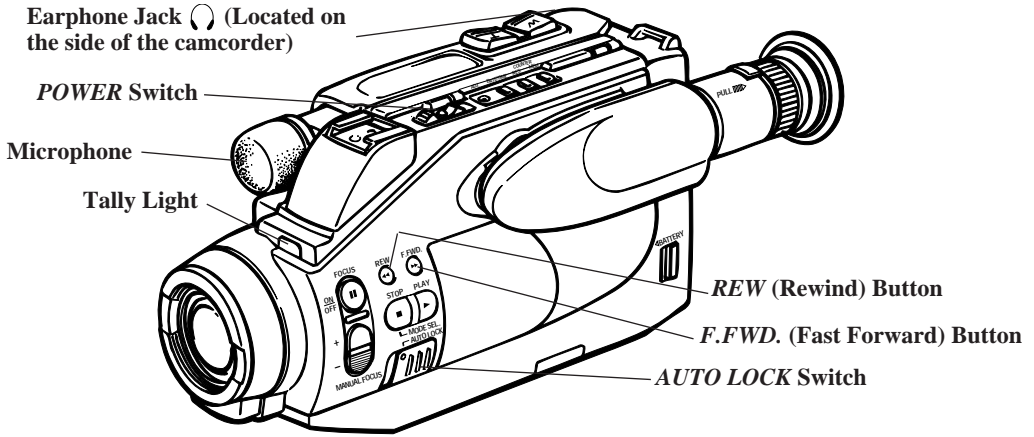

Camera Edit

The camera edit feature allows you to use the *F.FWD.* (fast forward) and *REW* (rewind) buttons on the camcorder (or the *SCENE SEARCH +* and *-* buttons on the remote control) to precisely position the tape while the camcorder is in the record-pause mode.

- Press and hold the *REW* (rewind) button on the camcorder (or the *SCENE SEARCH -* button on the remote control) to visually search the recorded tape in reverse.
- Press and hold the *F.FWD.* (fast forward) button on the camcorder (or the *SCENE SEARCH +* button on the remote control) to visually search forward on the recorded tape.

When you release the buttons, the camcorder will return to the record-pause mode at that point on the tape.

Quick Review

When the camcorder is in the record-pause mode, press and release the *REW* button to review the last few seconds of recorded material in the viewfinder. The camcorder will return to the record-pause mode.

Note: Do not hold the *REW* button, or the camcorder will go into camera edit.

Flying Erase Head

A separate erase head is mounted on the spinning headwheel (hence the term “flying”).

This allows you to make clean edits without the “glitches” or “rainbow noise” that may occur at the beginning and end of each recording.

Earphone Jack

Plug an optional earphone into this jack to privately listen while recording or playing back a tape.

AUTO LOCK Switch

When the *AUTO LOCK* switch is in the *AUTO LOCK* position, the camcorder will automatically control the focus and other recording features. When you press the thumb trigger to start recording, the *REC* and *PAUSE* indicators will briefly appear twice their normal size in the viewfinder to alert you that the *AUTO LOCK* switch is in the *AUTO LOCK* position. *Details are on pages 26-27.*

Note: When the *AUTO LOCK* switch is in the *AUTO LOCK* position, you cannot manually control the focus or preset program modes.

Tape Positioning

When the *POWER* switch is in the *PLAY* position and the camcorder is stopped, you can quickly fast-forward or rewind the tape.

- Press the *F.FWD.* (fast-forward) button to fast-forward the tape. Press the *STOP* button to stop fast-forwarding.
- Press the *REW* (rewind) button to rewind the tape to the beginning. Press the *STOP* button to stop rewinding.

Microphone

The microphone picks up the sound during a recording. It is more sensitive to sounds coming from the direction the lens is pointed.

Tally Light

The tally light on the front of the camcorder flashes when the camcorder is in the record-pause mode.

- During recording, the tally light will turn off if you start recording with the thumb trigger on the camcorder or place the *ON/POWER SAVE* lever in the *POWER SAVE* position.
- During recording, the tally light will light continuously if you start recording with the *RECORD START/STOP* button on the remote control.

Date and Time Display

Installing the Battery for Time and Date Display

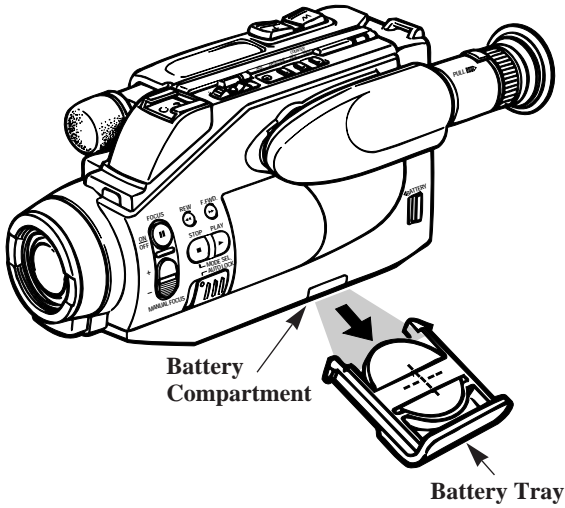

Caution: Lithium battery. Must be disposed of properly.

Never handle punctured or leaking batteries. May cause burns or personal injury.

Can cause death or injury if swallowed.

Keep out of the hands of children. If swallowed, consult a physician immediately for emergency treatment.

Never use metallic tweezers to hold the battery, and never short circuit the + and – sides of the battery.

1. Locate the clock battery compartment on the bottom side of the camcorder.
2. Pull the battery tray out from the battery compartment.
3. Insert the clock battery with the "+" terminal facing up as illustrated above.
4. Replace the battery tray in the camcorder.

Notes: Under normal conditions, the lithium battery should last about one year. When the battery is expired the date display will show "88:88". After the lithium battery has been replaced, the date and time will need to be reset.

Setting the Time and Date Display in the Viewfinder

The time and date (or only the date) can be recorded on your tape. Whenever one of the displays appear in the viewfinder, it will be recorded on the tape. You can choose to record only the date, both the date and time, or neither.

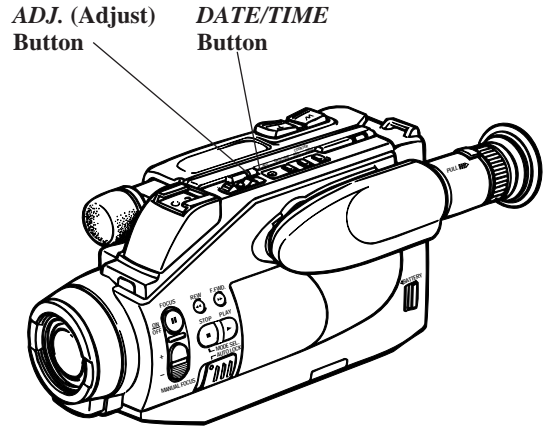

1. Install the clock battery as described in the previous column.
2. Attach a power supply to the camcorder. Press and hold the small button on the *POWER* switch while you slide it in the *CAM* (camera) position. Place the *ON/POWER SAVE* lever in the *ON* position.
3. Use a straightened paper clip or pen to press and hold the *ADJ.* (adjust) button for about one second. The reset date (1. 1. 1992) and time (AM 12:00:00) will appear in the viewfinder.
4. The month will be flashing. Repeatedly press the *DATE/TIME* button until the correct month appears

Display in Viewfinder

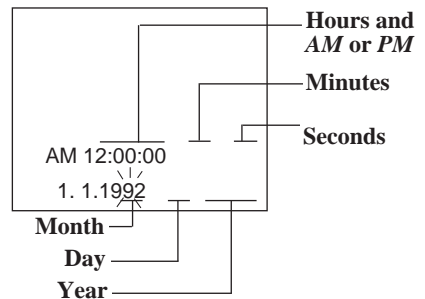

(continued on the next page)

Date and Time Display (continued)

- Then, press the *ADJ.* button. The flashing cursor will move to the next part of the display.
- Repeat steps 4 and 5 until you have entered the correct month, day, year, hour including *AM* or *PM*, and minute.
- After setting the minutes, press the *ADJ.* button to start the seconds. The seconds counter will start with "00".

Notes: To correct the date or time after the clock has been started, repeat steps 3-7.

If "88:88" appears instead of the date display, the lithium clock battery is expired. Replace the battery and reset the time and date.

Recording Date and Time (or Date) on Your Tape

If you see the date and time (or date) display in the viewfinder while you are recording, it will be recorded on your tape. If you do not want it recorded, press the *DATE/TIME* button until the displays are removed from the viewfinder.

Press <i>DATE/TIME</i> Button	To Display in Viewfinder and Record on the Tape
Press Once	Date Only
Press Again	Date and Time
Press Again	Neither Date nor Time

Electronic Viewfinder

The camcorder's electronic viewfinder (EVF) is a miniature black-and-white monitor that displays the picture seen by the camcorder when recording. The viewfinder can also be used for viewing the tape during playback.

Electronic Viewfinder in Operating Position
(PULL here to extend viewfinder.)

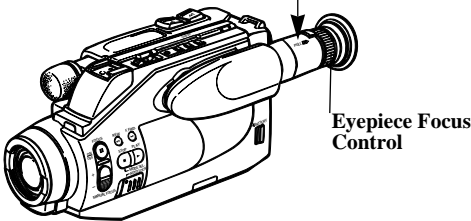

Caution: When carrying the camcorder with the shoulder strap, rotate the EVF down. This helps prevent possible damage to the viewfinder from bumping against your body as you move.

Eyepiece Focus Control

The eyepiece focus control lets you set the focus of the viewfinder for your personal vision. If you wear eyeglasses, you can probably operate the camcorder without them.

It's easiest to set the correct focus by focusing on one of the viewfinder's on-screen displays (such as the date). Pull the viewfinder out into operating position. Look through the viewfinder and adjust the eyepiece focus control for your vision.

The eyepiece focus control does not affect the focus of the picture actually recorded by the camcorder.

Tilt Adjustment

For convenient viewing, the viewfinder can be raised 90°.

Caution: Do not force the viewfinder to rotate completely around. This will damage the viewfinder and/or the camcorder.

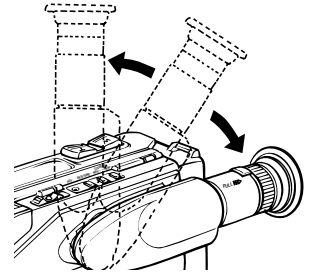

Cleaning the Viewfinder

You may occasionally want to clean the viewfinder. Follow the steps below.



- Fully extend the viewfinder, and then slightly push it back.
- Rotate the viewfinder in the counter-clockwise direction to remove the eyecup piece.
- Use an optional air blower *available from most camera stores* to clean the viewfinder.

Displays in Viewfinder

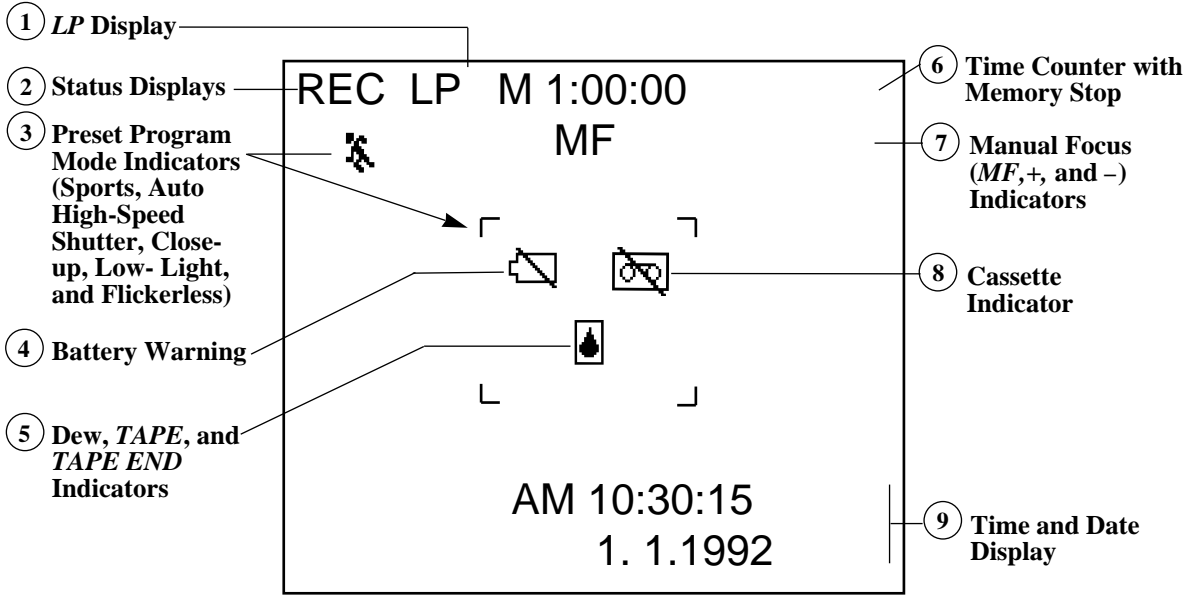

The camcorder has several displays in the electronic viewfinder that tell what the camcorder is doing, and aid in the ease of operation.

1 LP Indicator

The *LP* indicator appears when you are playing back a tape that was recorded at the *LP* speed.

2 Status Displays

One of the following displays will appear in the viewfinder to let you know what the camcorder is doing. These displays are not recorded on the tape when they appear in the viewfinder.

- *REC* appears when the camcorder is recording.
- *PAUSE* flashes when the camcorder is in the record-pause mode.
- *FF* appears when the tape is fast forwarding, and *REW* appears when the tape is rewinding.
- *STOP* appears when the camcorder is stopped during playback.
- *PLAY* appears when the camcorder is playing back a tape.

Note: When you start or stop recording, a larger *REC* or *PAUSE* indicator will briefly flash below the status display area to let you know that the *AUTO LOCK* switch is in the *AUTO LOCK* position.

3 Preset Program Mode Indicators (Sports, Auto High-Speed Shutter, Close-up, Low-Light, and Flickerless)

Slide the *AUTO LOCK* switch out of the *AUTO LOCK* position, and then repeatedly press the *MODE SEL.* (select) button to select one of the

camcorder's preset program modes ([] , [X] , [HS] , [↓] , [↑] , or []). The indicator for the mode selected will appear in the viewfinder. This indicator will not be recorded on the tape when it appears in the viewfinder. No indicator appears when the auto mode is selected. *Details are on page 27.*

4 Battery Warning

The battery warning indicator appears when it is time to recharge the battery pack.

5 Dew, TAPE and TAPE END Indicators

- The dew indicator [] appears when excessive moisture has entered the camcorder or cassette. The camcorder's buttons will not operate except to eject the cassette. Press the *EJECT* button and remove the cassette from the camcorder. Place the camcorder in a warm, dry area until the [] indicator disappears (approximately one hour). When the [] indicator no longer appears in the viewfinder, the camcorder will operate.
- *TAPE* appears in the viewfinder when there is approximately five minutes of recording time left on the tape.
- *TAPE END* appears in the viewfinder during recording when the end of the tape is reached.

6 Time Counter with Memory Stop

- Press the *COUNTER RES.* (reset) button to reset the counter to “0:00:00” when you start recording or playing back a tape.
- Press the *COUNTER MEM* (memory) button to turn on the time counter’s memory-stop feature. An *M* appears in front of the time counter display. Press the *COUNTER MEM* button again to remove the *M* and turn off the memory-stop feature.
- These displays will not be recorded on the tape when they appear.
- *Details are on page 28.*

7 Manual Focus (*MF*, *MF+*, and *MF-*) Indicator

- Slide the *AUTO LOCK* switch to the left (out of the *AUTO LOCK* position). Then press the *FOCUS ON/OFF* button to turn off auto focus and focus manually.
- The *MF* indicator will appear in the viewfinder during manual focus.
 - Focus manually using the *MANUAL FOCUS +/-* button.
 - During manual focus, *MF+* or *MF-* will appear in the viewfinder when using the *MANUAL FOCUS +/-* button.
 - This display will not be recorded on the tape when it appears.
 - Press the *FOCUS ON/OFF* button again to return to auto focus. No indicator appears when using auto focus.

8 Cassette Indicator

This indicator appears if there is no cassette in the camcorder, or if you try to record on a cassette that has its record-protect tab closed. It also appears if there is moisture in the cassette.

9 Time and Date Display

After the time and date have been set, press the *DATE/TIME* button to display the time and date (or date) in the viewfinder. The time and date display only appears when the camcorder is recording or in the record-pause mode (*POWER* switch in the *CAM* position).

- This display will be recorded on the tape whenever it appears in the viewfinder.
- Repeatedly press the *DATE/TIME* button to remove this display from the viewfinder.
- “88:88” appears instead of the time and date if the time and date have not been set. It also appears when the clock battery is not installed correctly or it needs to be replaced.
- *Details are on pages 22-23.*

Power Zoom Buttons

T=Telephoto

W=Wide Angle

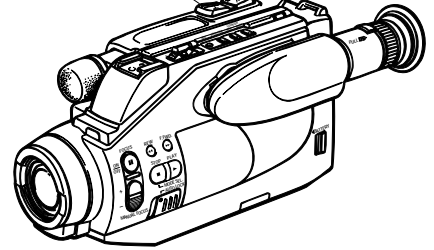

The 8:1 motorized zoom lens allows you to zoom in and out for close-ups or wide-angle shots just by pressing one of the power zoom buttons.

The zoom buttons are easily controlled by your index and middle fingers when you hold the camcorder through the handstrap.

- Press the button labeled “T” to move the lens in the telephoto (close-up) direction.
- Press the button labeled “W” to move the lens in the wide-angle direction.

Notes: Image vibration is more noticeable when zooming in to film close-up shots. If possible use a tripod or make sure that the camcorder is kept steady.

When the camcorder’s *CAM/OFF/PLAY* switch is set to the *OFF* position, the zoom ratio will automatically return to the full wide-angle position.

When you place the *ON/POWER SAVE* lever in the *POWER SAVE* position and then back in the *ON* position, the zoom ratio will remain the same as before you put it in the *POWER SAVE* position.

Focusing Your Camcorder

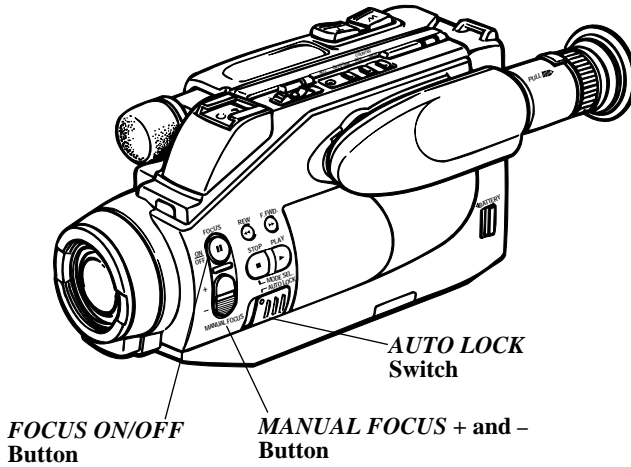

Auto Focus

If you want the camcorder to focus for you automatically, set the *AUTO LOCK* switch to the *AUTO LOCK* position.

Notes: The camcorder will automatically focus on any subject at a distance of three feet or more from the lens. When a subject is closer than three feet, press the power zoom button “W” to change to a wide-angle position where the subject will be in focus.

When zooming in on a distant subject from the wide-angle position, auto focus may not function properly due to the instability of the image. Let auto focus adjust for the full zoomed-in position, and then use a tripod for stable images. The subject will then stay in focus while using the power zoom buttons.

Manual Focus

Under certain conditions, such as those listed, you may need to focus manually.

- When filming two subjects—one nearby and one distant.
- When filming subjects in very low light.
- When filming a horizontally striped subject.
- When filming subjects with little or no contrast in the picture.

To focus manually.

1. Slide the *AUTO LOCK* switch to the left (out of the *AUTO LOCK* position).
2. Press the power zoom button labeled “T” and zoom in on the subject.
3. Press the *FOCUS ON/OFF* button to select manual focus. *MF* will appear in the viewfinder.
4. Adjust the focus by pressing the + or – side of the *MANUAL FOCUS +/-* button.
 - *MF+* will appear in the viewfinder when focusing in the + direction.
 - *MF–* will appear in the viewfinder when focusing in the – direction.
5. Use the power zoom buttons to select desired zooming range.

Note: When the *CAM/OFF/PLAY* switch is set to *OFF*, the focus will reset to auto focus when power is restored. Manual focus will remain selected when you place the *ON/POWER SAVE* lever in the *POWER SAVE* position and then restore power by returning it to the *ON* position.

Preset Program Modes

The camcorder has several preset program modes which allow you to select a mode that fits your particular recording situation. The camcorder will automatically set shutter speed, white balance, and iris. Manual or auto-focus can be used during any of the preset program modes. To select one of the preset program modes, follow the steps below.

1. Place the camcorder in the record-pause mode.
2. Slide the *AUTO LOCK* switch to the left (out of the *AUTO LOCK* position).
3. Repeatedly press the *MODE SEL.* (select) button to select the preset program mode that best fits your recording conditions. See the chart below to determine which mode to use.

Notes: If you want the camcorder to remember the preset program mode and settings you selected during recording breaks, place the *ON/POWER SAVE* lever in the *POWER SAVE* position. The camcorder will automatically return the settings to the auto mode if the power is turned off using the *POWER* button.

Auto focus will automatically reset whenever you select a new preset program mode.

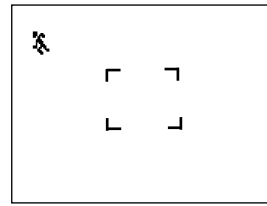

Display in Viewfinder with the Sports mode selected

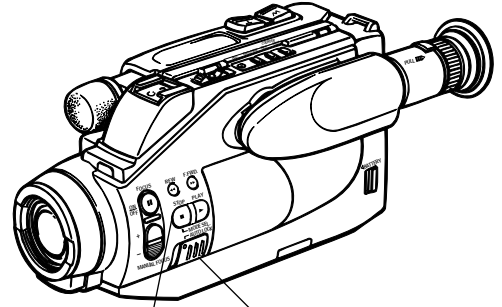

MODE SEL. (Select) Button

AUTO LOCK Switch

Mode	Shutter Speed	Indicator	Auto-Focus Area	Recording Conditions
Auto mode	1/60 second.	None	Normal	Use under normal conditions.
Sports	1/60 ~ 1/250 second. (depending on brightness)		Center Frame Area Only (9 feet and farther)	For filming sporting events, football games, etc. • Colors may change if this mode is used indoors with fluorescent lighting.
Auto high speed shutter	1/250 ~ 1/10,000 second (depending on brightness)		Normal	For capturing fast movements such as a golf swing, tennis swing, etc. • Colors may change if this mode is used indoors with fluorescent lighting.
Close-up	1/60 second		2/5 inch~78 inches	For filming subjects, such as flowers or insects, at a short distance. • This mode automatically sets the zoom to the wide-angle position and the focus to about 2 inches from the lens. The focus can then be adjusted on any subject in a range of 2/5 inch to 78 inches from the lens.
Low Light	1/60 second		Normal	For best results when filming indoors, under low light conditions. • If the camcorder makes too many focus adjustments, this may indicate that the subject is too bright. In this case select the auto mode shown above or use manual focus.
Flickerless	1/100 second		Normal	When recording in a foreign country under fluorescent lighting that uses 50 Hz. electric current (some parts of Europe and Asia).

Time Counter with Memory Stop

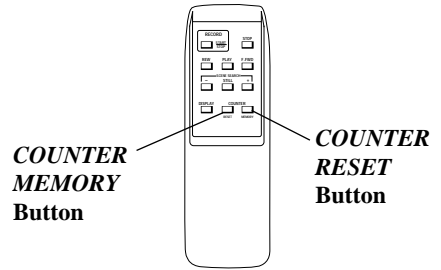
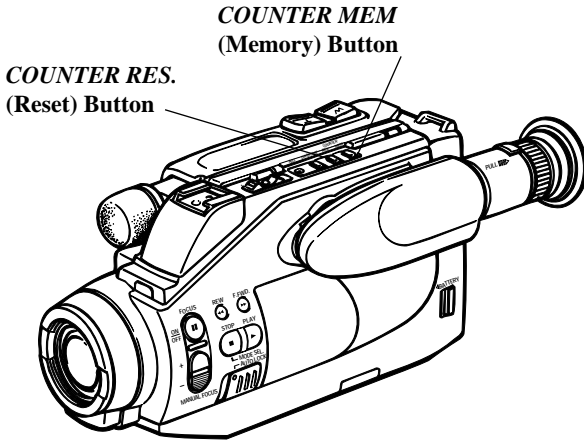

Time Counter

The time counter display shows the actual time elapsed when recording a program or playing back a segment of a pre-recorded tape.

The time counter also helps you quickly locate the end of recorded segments. Note the time counter reading when you are finished recording or playing back a tape. For example, you recorded a 10-minute segment. Later, if you want to locate the end of your recording, you can insert the cassette and fast-forward the tape until the time counter reads "0:10:00".

Before you start to record or playback a tape, press the *COUNTER RES.* (reset) button to set the counter to "0:00:00".

Memory Stop Feature

The memory-stop feature helps you locate a certain point on the tape. This is useful if you want to review a section immediately after recording or return to the same place on the tape several times during playback. When memory stop is turned on, the tape will stop automatically during rewind or fast forward when the time counter reaches "M 0:00:00".

1. Press the *COUNTER MEM* (memory) button to turn on the memory stop feature. An "M" appears in front of the time counter in the viewfinder.

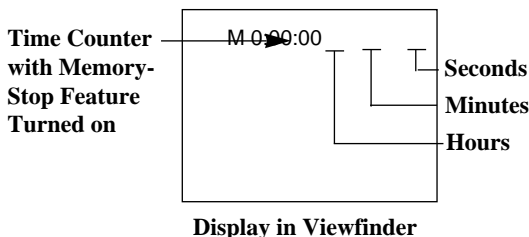

2. Locate the place on the tape you want to return to and press the *COUNTER RES.* (reset) button to set the time counter to "M 0:00:00".
3. Continue to record or play the tape. When you want to return to the place you marked, press the thumb trigger to stop recording or the *STOP* button to stop playing back the tape.
4. Make sure the *CAM/OFF/PLAY* switch is in the *PLAY* position, and then press the *REW* (rewind) button. The tape will rewind to the time counter reading of "M 0:00:00".

Notes for Memory Stop: The corresponding buttons on the remote control can be used to operate the camcorder.

Whenever the time counter is displayed, you can reset it to 0:00:00 by pressing the *COUNTER RES.* button.

If you rewind the tape farther back than a counter reading of "0:00:00", a minus will appear in front of the time counter display.

Whenever memory stop is turned on, the camcorder will stop rewinding or fast forwarding when the counter reaches "M 0:00:00". To continue rewinding or fast forwarding, press *REW* or *F.FWD.* again.

There may be a small difference between the actual length of the tape and the counter reading.

The memory stop feature can be turned on at any time by pressing the *COUNTER MEM.* button. Press the *COUNTER MEM.* button again to turn memory stop off and remove the *M* in front of the time counter.

If the tape does not stop at the exact memory location, use the *REW* and *F.FWD* buttons.

Camcorder Recording Tips

Recording Tips

- Practice recording under a variety of lighting conditions. This will help you respond quickly whenever you see a scene you want to record.
- When using manual focus, it is easier to make professional looking videos if you check the focus before you start recording. Use your camcorder's zoom to help you focus manually. Before you start recording, zoom in on your subject and adjust the focus until you see a clear image in the viewfinder. Then zoom back to where you want to record. If the subject-to-camcorder distance does not change, the subject will remain in sharp focus over the entire zoom range.
- Do not move the camcorder rapidly from side-to-side while recording. A steady, gradual "pan" avoids blurring and "jitter".
- Use the viewfinder to make sure the camcorder is level while recording or your scenes will appear "tilted".
- Try to make sure indoor scenes are well-lit. This improves picture quality and color reproduction.
- Do not bump or tap the camcorder's microphone while recording because this sound will be recorded.
- Be aware of video and audio backgrounds. Background details barely noticed while you are taping may show up as visual "clutter" on your recording. Background noises (especially TV sets, radios, household appliances, traffic sounds, etc.) can detract from the sound you want to record.
- Avoid long "still" shots of landmarks and scenic attractions. Recordings are more interesting if they include people and details. "Local color" will give travel videos lasting appeal. Consider recording a familiar or landmark scene from an unfamiliar vantage point for added interest. Remember to check the lighting before starting to record.
- Include close-up shots of individuals when taping family outings or group functions.
- Make a video recording of your home and contents to store in a safe place in case of fire or theft.

Holding Your Camcorder

- Hold the camcorder horizontally. Keep your feet slightly apart and your upper arms close to your body.
- When possible rest your elbows on a table or other stable surface to help keep the camcorder steady.
- If you want to film at different angles, you may raise the viewfinder 90°.
- Standing against a wall may give your recordings more stability.
- Use an optional tripod for stable images.

Traveling Tips

- Write down your camcorder's serial number and keep it separate from the camcorder when traveling. If your camcorder is lost or stolen, you will be able to identify it.
- Make sure you have any plug adapters that you may need before taking your camcorder to other countries. Consult your RCA dealer for advice.
- Use extra care to avoid damage to your camcorder and accessories when operating them at a beach or pool. Spray, sand, and dust should be avoided. If your lens has been exposed to the elements, clean it only with proper lens cleaning supplies.
- Carry your camcorder in a carrying case when traveling. *See page 4* for a case especially designed for this camcorder. An ordinary suitcase or carry bag does not offer the protection your camcorder needs. Treat your camcorder as carry-on luggage to protect it from rough handling.

Care and Maintenance

Camcorder Care and Storage

- Keep dust and grit from entering the camcorder's cassette door. Dust and grit are abrasive and will cause excessive wear both to the camcorder's recording/playback heads and cassettes.
- We recommend RCA video cassettes be used with this camcorder. These cassettes have been manufactured to our critical specifications. Use of cassettes not meeting these specifications may reduce the camcorder's performance or contaminate the heads resulting in a snowy picture or no picture during playback.
- Always replace the lens cap on the lens when the camcorder is not in use.
- Do not touch the lens with your fingers. The oil from your skin can damage the lens. Always use lens-cleaning tissue and commercially prepared cleaning solution designed for use on camera lens. Improper cleaning may scratch the lens.
- Before handling your camcorder, make sure your hands and face are free from any chemical products such as suntan lotion, as it may damage the finish.
- The camcorder can be damaged by improper storage or handling. Do not subject the camcorder to swinging, shaking, or dropping.
- Do not store the camcorder in temperatures below -22°F (-30°C) or above 149°F (65°C).
- When the camcorder is not in use, always remove the cassette and AC adapter/charger or battery.
- Retain the original carton for future storage or shipping purposes.

Cassette Care and Storage

- When you are finished with a cassette, rewind it, and remove it from the camcorder. Label your cassettes before storing them.
- When you are finished recording, close the cassette's record-protect (safety) tab to prevent accidental erasure.
- Store cassettes vertically in their protective boxes at normal room temperatures. Do not leave your camcorder or cassettes in a car or outdoors for an extended period. Excessive heat or cold may damage your cassettes.
- Do not touch or cover the small holes in the cassette or use cassettes with damaged or spliced tape.
- Keep dust from entering the cassette compartment. All dust is abrasive and will cause excessive wear on the tape and the camcorder's recording or playback heads.
- Keep the cassette away from strong magnetic fields such as electric motors and other devices.
- Do not use a cassette if it has been damaged or exposed to moisture. The tape may jam and damage your camcorder.

Things to Avoid

- Do not attempt to disassemble your camcorder. There are no user-serviceable parts inside.
- Avoid operating your camcorder immediately after moving it from a cold location to a warm location. Give the camcorder 1-1/2 to 2 hours to reach a stable temperature before inserting a cassette. When the camcorder is moved from cold to warm, moisture may cause the tape to stick to the headwheel and damage the headwheel or tape.
- Do not aim your camcorder at the sun or other bright objects.
- Do not leave your camcorder in direct sunlight. Doing so could permanently damage the camcorder's internal parts.
- Do not operate the camcorder in extremely humid environments.
- Do not operate the camcorder for extended periods in temperatures below 40°F (4°C) or above 95°F (35°C).
- Do not expose the camcorder or adapter/charger to rain or moisture. If either component becomes wet, turn off the power and take the unit to an Authorized RCA Compact Camcorder Servicenter.
- Never attempt to force open the cassette door. If the battery reaches its empty level during recording, the camcorder will shut off, but the battery should have enough reserve power to eject the cassette. If the camcorder does not eject the cassette, power your camcorder with the adapter/charger or recharge the battery.
- Do not use an adapter/charger or batteries other than the ones specified. Use of the wrong accessories may cause damage to the camcorder.

Viewfinder Playback

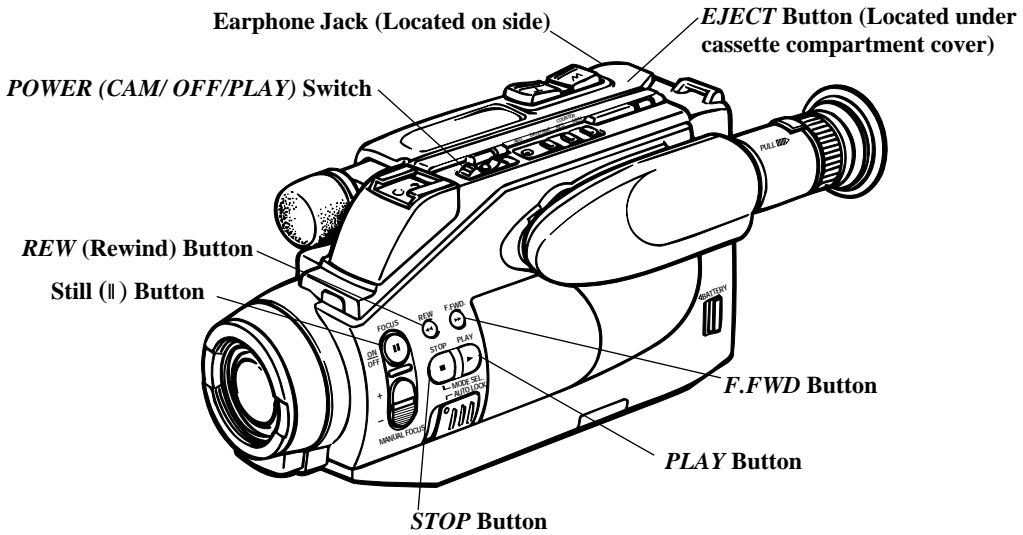

Viewfinder playback is the simplest way to watch tapes using the camcorder. This method is generally used only to review scenes immediately after recording because the display is in black and white. If you want to privately listen during viewfinder playback, you may connect an optional earphone to the earphone  jack.

To play back a tape through the viewfinder, follow these steps:

1. Slide the *POWER* switch to the *PLAY* position.
2. Insert the cassette you want to playback.
3. Press the *PLAY* button to begin playback.
 - During playback, press the still (II) button to “stop the action” and view one frame of the tape. Press the still (II) button again (or the *PLAY* button) to return to normal playback.
4. Press the *STOP* button when you are finished.
 - During playback, press and hold the *F.FWD* (fast forward) or *REW* (rewind) button if you want to visually search the tape in forward or reverse. Release the button to return to normal playback.

Notes: The corresponding buttons on the remote control can be used to operate the camcorder.

The camcorder can play back tapes recorded in SP or LP speed. The *LP* indicator appears in the electronic viewfinder when a tape recorded at LP speed is being played. Tapes recorded at SLP speed cannot be played back in this camcorder.

During still and search operations, it is normal for streaks to appear in the picture.

The sound is muted during special playback operations.

Caution: Still is designed for momentary interruptions and should not be used for an extended period of time. If the camcorder remains in the still mode for more than five minutes, it will automatically move the tape away from the spinning heads to prevent excessive tape wear.

Playback on a TV (or VCR) Using the Antenna Connection

To connect your camcorder to a TV using the antenna connection, you will need the RF output adapter and coaxial RF cable that came packed with your camcorder. If your TV is already connected to a VCR, you can attach the camcorder to the VCR and watch what the camcorder is recording or playing on the TV.

The unauthorized recording of television programs and other recorded material may infringe the rights of others.

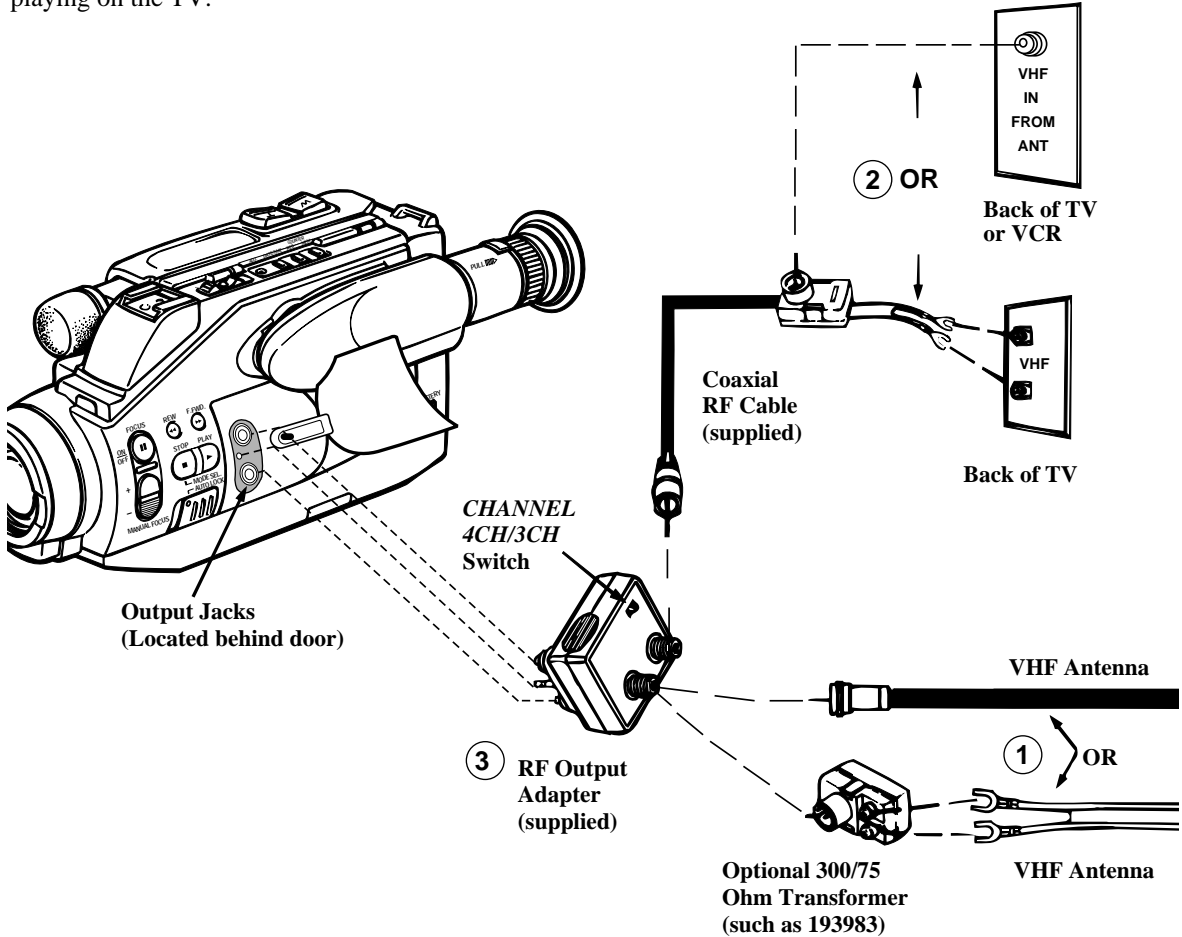

Installation

- 1 Disconnect the VHF antenna from your TV (or VCR). Connect the antenna to the *VHF IN* connector on the RF output adapter if you are going to leave the adapter connected to the TV (or VCR).
Note: If your VHF antenna is the flat twin-lead type attached by two screws, you will also need an optional 300/75 ohm transformer, such as 193983 shown on page 6.
- 2 Attach one end of the coaxial RF cable to the *VHF OUT* connector on the adapter and attach the other end to the VHF input on your TV (or VCR) as shown.
- 3 Attach the RF output adapter's plug to the output jacks located behind the door on the side of the camcorder as shown above.

Playback on a TV Using the Antenna Connection (continued)

Playback Operation and How to Copy Tapes on the VCR

1. Set the *CHANNEL 4CH/3CH* switch on the RF output adapter to *4CH* or *3CH*.
 2. A. Camcorder connected directly to TV: Turn on the TV and tune it to channel 3 or 4.
B. Camcorder connected to VCR that is already connected to TV: Turn on VCR and tune it to channel 3 or 4". Operate the TV as you normally do to see the signal coming from the VCR.
 3. Attach a power supply, and slide the camcorder's *POWER* switch to the *PLAY* position. Insert the cassette you want to play back.
 4. Press the *PLAY* button to begin playback.
 - During playback, press the still (II) button to "stop the action" and view one frame of the tape. Press the still (II) button again (or the *PLAY* button) to return to normal playback.
- Caution:** Still is designed for momentary interruptions, and should not be used for extended time periods. If the camcorder remains in the still mode for more than five minutes, the camcorder will automatically move the tape away from the spinning heads to prevent excessive tape wear.
- During playback, press and hold the *F.FWD* (fast forward) or *REW* (rewind) button if you want to visually search the tape in forward or reverse. Release the button to return to normal playback.
 5. To copy what the camcorder is playing, place a blank cassette in the VCR, and press the VCR's *RECORD* button.
 6. Press the *STOP* button when you are finished.

Notes: The corresponding buttons on the remote control can be used to operate the camcorder.

The camcorder can play back tapes recorded in SP or LP speed. The *LP* indicator appears in the electronic viewfinder when a tape recorded at LP speed is being played. Tapes recorded at SLP cannot be played back on this camcorder.

During still and search operations, it is normal for streaks to appear in the picture.

The sound is muted during special playback operations.

Viewing What the Camcorder Is Recording

1. A. Camcorder connected directly to TV: Turn on the TV and tune it to channel 3 or 4.
B. Camcorder connected to VCR that is already connected to TV: Turn on VCR and tune it to channel 3 or 4". Operate the TV as you normally do to see the signal coming from the VCR.
Note: When the camcorder is used as a camera, turn the TV's volume down to prevent a high-pitched squeal caused by feedback.
2. Set the *CHANNEL* switch on the RF output adapter to the same channel you selected on the TV (or VCR).
3. Attach a power supply and slide the camcorder's *POWER* switch to the *CAM* position. Insert the cassette you want to record on. Make sure the *ON/POWER SAVE* lever is in the *ON* position. Press the thumb trigger on the camcorder (or the *RECORD START/STOP* button on the remote control) to start recording. You can watch what you are recording on the TV screen.

Seeing the Camcorder's displays on the TV Screen.

When the camcorder is connected to a TV, press the *DISPLAY* button on the remote control to see the camcorder's viewfinder displays on the TV screen. Press the *DISPLAY* button again to remove the displays.

Normal TV Viewing

For normal TV viewing, you may leave the RF output adapter hooked up to the TV (or VCR). Just disconnect the adapter's plug from the camcorder or turn off the camcorder's power.

Note to Cable TV Installer

This reminder is provided to call your attention to Article 820-40 of the National Electrical Code (Section 54 of Canadian Electrical Code, Part I), that provides guidelines for proper grounding and, in particular, specifies that the cable ground shall be connected to the grounding system of the building as close to the point of cable entry as practical.

Playback on TV (or VCR) Using *AUDIO/VIDEO IN* Jacks

To connect your camcorder to a TV monitor (or VCR) using *AUDIO/VIDEO IN* jacks, you will need optional audio/video cables. If your TV is already connected to a VCR, you can attach the camcorder to the VCR and watch what the camcorder is recording or playing on the TV.

The unauthorized recording of television programs and other recorded material may infringe the rights of others.

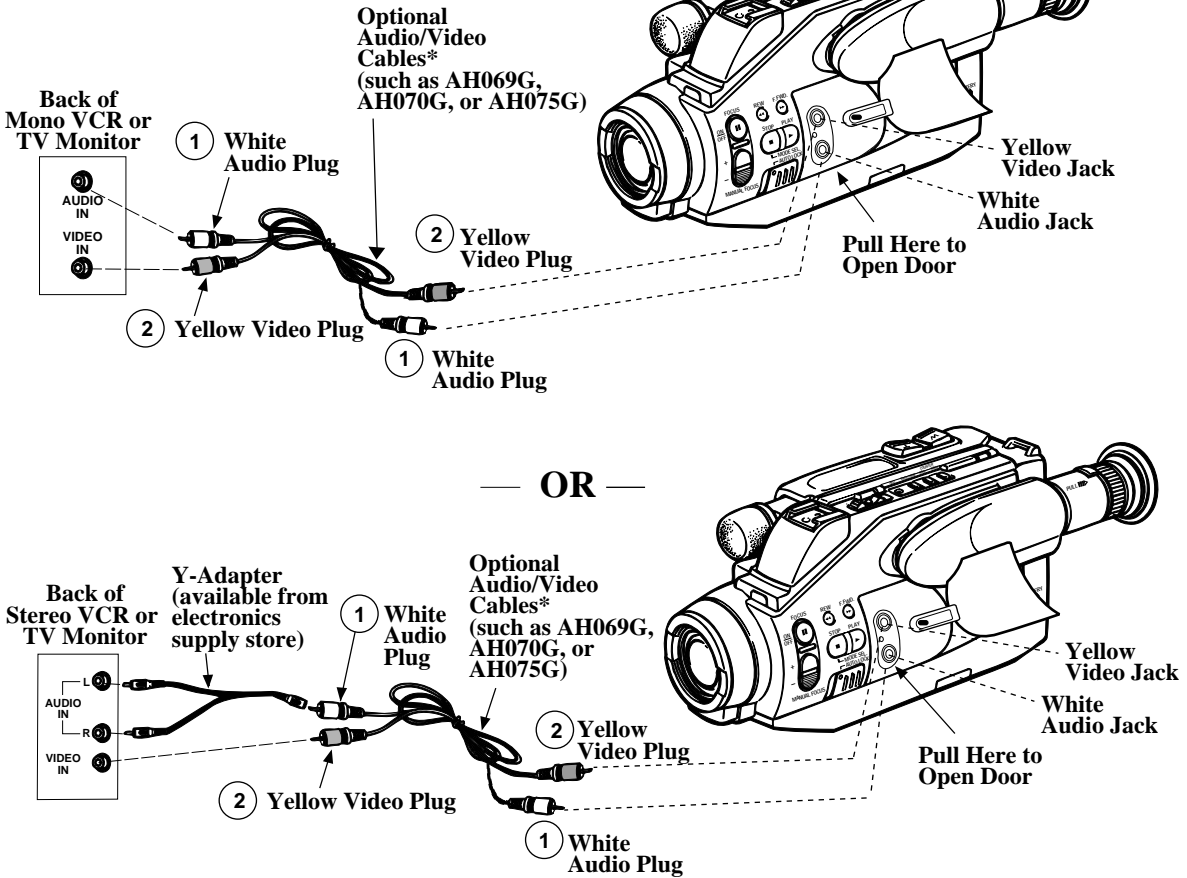

Installation

- 1 Attach one end of an optional audio/video cable (such as AH069G, AH070G, or AH075G) to the *AUDIO IN* jack on the TV (or VCR) and the other end to the white audio jack located under the door on the side of the camcorder.
- 2 Attach one end of another optional audio/video cable to the *VIDEO IN* jack on the TV (or VCR) and the other end to the yellow video jack located under the door on the side of the camcorder.

Note: If your TV (or VCR) has stereo *AUDIO* jacks, attach the *AUDIO* plug to the one labeled *MONO*. If one is not labeled *MONO*, you may need a Y-adapter to hear sound from both channels.

*Optional accessories are available from your dealer or electronics supply store. *Mail order form is on page 5.*

Playback on TV (or VCR) (continued)

Playback Operation and How to Copy Tapes on the VCR

1. A. Camcorder connected directly to TV monitor:
Turn on the TV and tune it to the video input channel.
B. Camcorder connected to VCR that is already connected to TV: Turn on VCR and place it in the “line” or “camera mode”. (If your VCR does not have a “line” or “camera mode”, consult the VCR owner’s manual.) Operate the TV as you normally do to see the signal coming from the VCR.
2. Attach a power supply and slide the camcorder’s *POWER* switch to the *PLAY* position. Insert the cassette you want to playback.
3. Press the *PLAY* button to begin playback.
 - During playback, press the still (II) button to “stop the action” and view one frame of the tape. Press the still (II) button again (or the *PLAY* button) to return to normal playback.

Caution: Still is designed for momentary interruptions, and should not be used for extended time periods. If the camcorder remains in the still mode for more than five minutes, the camcorder will automatically move the tape away from the spinning heads to prevent excessive tape wear.

- During playback, press and hold the *F.FWD* (fast forward) or *REW* (rewind) button if you want to visually search the tape in forward or reverse. Release the button to return to normal playback.
4. To copy what the camcorder is playing, place a blank cassette in the VCR, and press the VCR’s *RECORD* button.
 5. Press the *STOP* button when you are finished.

Notes: The corresponding buttons on the remote control can be used to operate the camcorder.

The camcorder can play back tapes recorded in SP or LP speed. The *LP* indicator appears in the electronic viewfinder when a tape recorded at LP speed is being played. Tapes recorded at SLP cannot be played back on this camcorder.

During still and search operations, it is normal for streaks to appear in the picture.

The sound is muted during special playback operations.

Viewing What the Camcorder is Seeing (or Recording)

1. A. Camcorder connected directly to TV: Turn on the TV, and tune it to the video input channel.
B. Camcorder connected to VCR that is already connected to TV: Turn on VCR and place it in the “line” or “camera mode”. (If your VCR does not have a “line” or “camera mode”, consult the VCR owner’s manual.) Operate the TV as you normally do to see the signal coming from the VCR.
2. Attach a power supply and slide the camcorder’s *POWER* switch to the *CAM* position. Place the *ON/POWER SAVE* lever in the *ON* position, and insert the cassette you want to record on.
Note: When the camcorder is used as a camera, turn the TV’s volume down to prevent a high-pitched squeal caused by feedback.
3. Press the camcorder’s thumb trigger (or the remote control’s *RECORD START/STOP* button) to begin recording. You can watch what the camcorder is seeing (or recording) on the TV screen.

Seeing the Camcorder’s displays on the TV Screen.

When the camcorder is connected to a TV, press the *DISPLAY* button on the remote control to see the camcorder’s viewfinder displays on the TV screen. Press the *DISPLAY* button again to remove the displays.



Trouble Checks

Troubles sometimes are caused by simple “faults” that you can easily correct without the help of a service technician by first checking a few basic remedies.

Before you call or take your camcorder to an Authorized RCA Compact Camcorder Servicenter,

look below for the type of trouble you are experiencing. Then perform the simple checks and adjustments listed for that trouble.

If service should be necessary, the warranty information lists what your warranty covers and explains how to get service.

Trouble	Checks and Adjustments
No power	<ul style="list-style-type: none"> • <i>ON/POWER SAVE</i> lever in <i>POWER SAVE</i> position. Place lever in <i>ON</i> position. • If using battery, it may need to be recharged. • If using AC adapter/charger, make sure it is plugged into a working outlet.
Won't record or playback	<ul style="list-style-type: none"> • If using AC adapter/charger, make sure it is plugged into a working outlet. • If dew indicator () appears in the viewfinder, there is moisture in the camcorder. Remove the cassette from the camcorder and let it dry naturally. • There may be no cassette in the camcorder. • Try ejecting and re-inserting the cassette. • The cassette tape may be broken, try another cassette. • You may have reached the end of the cassette, try rewinding it.
Won't playback	<ul style="list-style-type: none"> • <i>POWER</i> switch must be in <i>PLAY</i> position.
Won't record	<ul style="list-style-type: none"> • Record-protect tab has been closed. (<i>See page 20.</i>) • <i>POWER</i> switch must be in <i>CAM</i> (camera) position. • <i>ON/POWER SAVE</i> lever must be in <i>ON</i> position.
No picture in viewfinder	<ul style="list-style-type: none"> • Remove lens cap. • <i>ON/POWER SAVE</i> lever must be in <i>ON</i> position when <i>POWER</i> switch is in <i>CAM</i> (camera) position.
Tape stops during rewind or fast forward	<ul style="list-style-type: none"> • Time-counter memory may be on. Whenever an “<i>M</i>” appears with the time-counter display, the camcorder will stop rewinding (or fast forwarding) when counter reads “<i>M 0:00:00</i>”. Press the <i>REW</i> or <i>F.FWD</i> button again to continue rewinding or fast forwarding, or press <i>COUNTER MEM</i> (memory) button to turn off memory-stop feature.
Camcorder remains in “stop action” (play-pause) mode	<ul style="list-style-type: none"> • Press the still () (or <i>PLAY</i>) button to return to normal playback.

Trouble Checks (continued)

Trouble	Checks and Adjustments
Poor auto-focus operation	<ul style="list-style-type: none">• Make sure <i>AUTO LOCK</i> switch is in the <i>AUTO LOCK</i> position.• Scene is dark. Auto-focus may not work under this condition. <i>See page 26 for details on manual focus.</i>• Lens is smudged, and image appears unfocused.• Viewfinder eyepiece focus is misadjusted. (<i>See page 23.</i>)
Picture is too dark or subject too dark.	<ul style="list-style-type: none">• Select the best preset program mode for the recording situation. <i>See page 27.</i>
Viewfinder displays are out of focus	<ul style="list-style-type: none">• Try adjusting eyepiece focus control. <i>See page 23.</i>• Pull electronic viewfinder out to the extended operating position.
Date and/time (or date) were recorded on tape	<ul style="list-style-type: none">• Date and time or date will be recorded on tape whenever they appear in the viewfinder.• Press <i>DATE/TIME</i> button to remove them from viewfinder when recording.
Date and/or time are incorrect	<ul style="list-style-type: none">• Clock battery may need replacing. <i>See page 22.</i>• Date and/or time may need to be set. <i>See pages 22-23.</i>
Remote control will not operate camcorder	<ul style="list-style-type: none">• Aim remote control at remote control sensor on camcorder.• Remote control batteries may need replacing.• If <i>POWER</i> switch is in <i>CAM</i> position, the <i>ON/POWER SAVE</i> lever must be in <i>ON</i> position for camcorder to operate.• <i>POWER</i> switch must be in <i>CAM</i> or <i>PLAY</i> position for camcorder to operate.• Camcorder's remote control sensor is exposed to direct sunlight or strong artificial light. This may interfere with operation of camcorder by remote control.

Design Specifications

General

Power requirement: 6VDC
Power consumption: 5.8 watts (normal)
Weight: 1.7 lbs. (780g)
Dimensions: 4-3/5"(W) x 4-3/5"(H) x 10-1/5"(L)
(117 x 118 x 259mm)

Video Recorder Section

Format: 8mm
Record/Playback System:
Two video record/playback heads
One flying erase head
Headwheel Cylinder Diameter: 40 mm
Video Signal: EIA Standard NTSC Color

Camera Section

Scanning: 525 Lines/60 Fields/30 Frames
Image Sensor: 1/3" high-resolution,
solid-state CCD Imager
Tripod Mount: One 1/4" threaded hole
Lens: f1.8
8:1 (6-48mm)
Diameter: 37 mm
Earphone Jack: Monaural 8 ohm mini jack

This digital apparatus does not exceed the class B limits for radio noise emissions from digital apparatus set out in the Radio Interference Regulations of the Canadian Department of Communications.

L'interférence radioélectrique générée par cet appareil digital ne dépasse pas les limites de la classe B édictées par le Règlement sur les perturbations radioélectriques du Ministère Canadien des Communications.

All features and specifications are subject to change without notice.

Compact Camcorder Limited Warranty

What your warranty covers:

- Any defect in material or workmanship.
- 90 days for labor charges.
- One year for parts.

The warranty period for rental units begins with the first rental.

What we will do:

- Pay any Authorized RCA Compact Camcorder Servicenter the labor charges to repair your camcorder.
- Pay any Authorized RCA Compact Camcorder Servicenter for the new or, at our option, rebuilt replacement parts required to repair your camcorder.

How you get service:

- Check with your RCA Dealer or call 1-800-336-1900 for the Authorized RCA Compact Camcorder Servicenter nearest you. State that you have an RCA 8 millimeter camcorder.

If an Authorized RCA Compact Camcorder Servicenter is conveniently near you:

- Take your camcorder to the Authorized RCA Compact Camcorder Servicenter of your choice.
- Show the Servicenter Representative your sales receipt or other evidence of purchase date.
- Pick up your camcorder when repairs are completed.

If an Authorized RCA Compact Camcorder Servicenter is not located conveniently near you:

- Pack the camcorder so that it will not be damaged during shipping. (We recommend using the original carton and packing materials.) Include any cables and other accessories originally furnished with the camcorder.
- Include in the camcorder carton (1) a copy of your sales receipt or other evidence of purchase date, (2) your name and address, and (3) a brief description of the problem.
- Ship the camcorder to an Authorized RCA Compact Camcorder Servicenter.
- Pay any charges billed to you by the Servicenter for service not covered by the warranty.

What your warranty *does not* cover:

- Customer instruction. (Your owner's manual clearly describes how to install, adjust, and operate your camcorder. Any additional information should be obtained from your Dealer.)
- Installation and related adjustments.
- Cleaning of video/audio heads.
- Damage from misuse or neglect.
- Batteries for clock or other features.
- A camcorder that has been modified or incorporated into other products or is used for institutional or other commercial purposes.
- A camcorder purchased or serviced outside the USA.

How state law relates to this warranty:

- This warranty gives you specific legal rights, and you also may have other rights that vary from state to state.

Product registration:

- Please complete and mail the *product registration card* packed with your camcorder. It will make it easier to contact you should it ever be necessary. The return of the card is not required for warranty coverage.

If you purchased your camcorder in Canada:

- The Canadian warranty applies in place of this warranty.

Index

- Accessories, Included8
- Accessories, Optional4-7
- Accessory Shoe12
- Accessory, Order Form5-6
- Adapter/Charger, Safety
 - InstructionsInside Front Cover
- Adapter/Charger, Using16
- ADJ.* (Adjust) Button13,22-23
- Attaching the Shoulder Strap9
- AUTO LOCK* Switch10,12,21,27
- Auto Focus26
- Auto High-Speed Shutter Mode27
- Auto Mode27
- Batteries, Remote Control14
- BATTERY* Eject Lever12,18
- Battery Safety Precautions18
- Battery Warning18,24
- Battery, Care and Storage18
- Battery, Using Rechargeable17-18
- CAM/OFF/PLAY POWER* Switch10-11,12
- Camcorder, Powering16-19
- Camcorder, Turning On10
- Camcorder, Unpacking8
- Car Cord, Optional19
- Care and Maintenance30
- Care and Storage of the Battery18
- Cassette Care and Storage30
- Cassette Compartment10,13,20
- Cassettes, Inserting and Removing10,20
- Charging the Battery17
- Cleaning the Viewfinder23
- Clock Battery Compartment12,22
- Close-Up Mode27
- Compact Camcorder Limited Warranty39
- Connection, TV Using Antenna32-33
- Connection, TV Using *AUDIO/VIDEO*
 - Jacks34-35
- ContentsFront Cover
- Copying Tapes32-35
- COUNTER MEM* (Memory) Button13,24-25,28
- COUNTER MEMORY* Button14-15,24-25,28
- COUNTER RES.* (Reset) Button13,24-25,28
- COUNTER RESET* Button14-15,24-25,28
- Date and Time Display22-23,24-25
- Date and Time, Recording23
- Date and Time, Setting22-23
- DATE/TIME* Button13,22-23,25
- DC Car Cord, Optional19
- DC IN 6.5V* Jack13,16,19
- DC Power Cord8,16
- Design Specifications38
- Dew Indicator10,24
- DISPLAY* Button14-15,33,35
- Displays in Viewfinder24-25
- Earphone Jack13,21,31
- EJECT* Button10-11,13,20
- Electronic Viewfinder, Adjusting23
- Erase Protection20
- Eyepiece Focus Control10-11,12,23
- F.FWD* (Fast Forward)
 - Button12,14-15,21,31,33,35
- FF* Display24
- First-Time Operation8-13
- Flickerless Mode27
- Flying Erase Head21
- FOCUS ON/OFF* Button12,25,26
- Focusing Your Camcorder26
- Hand Strap10,13
- Important Safeguards2-3
- Important Safety InstructionsInside Front Cover
- Inserting and Removing Cassettes20
- Introduction8
- Lens12,30
- Lens Cap9,13
- Limited Warranty39
- Low Level Battery Warning18
- Low Light Mode27
- LP* Tape Speed Display24
- Maintenance and Care30
- Making Better Videos29
- MANUAL FOCUS* + and – Buttons12,24-25,26
- Manual Focus (*MF*, *MF+*, and *MF-*)
 - Indicators24-25,26
- Memory Stop Indicator24-25,28
- Memory-Stop Feature28
- Microphone12,21
- MODE SEL* Button24,27
- ON/POWER SAVE* Lever10-11,13
- OPEN* Button10,13,20
- Operation, First-Time8-13

Index (continued)

Optional Accessories	4-7	<i>SCENE SEARCH</i> + and – Buttons.....	14-15,21
Order Form, Accessory.....	5-6	Setting the Time and Date	22-23
Output Jacks (Yellow Video, DC, and White Audio)	12,32,34	Shoulder Strap Rings	9,13
<i>PAUSE</i> Display	24	Shoulder Strap, Attaching.....	9
<i>PLAY</i> Button	11,12,14-15,24,31,33,35	Solving Problems.....	36-37
<i>PLAY</i> Display	24	SP Speed	20
Playback.....	31-35	Special Features	21
Playback on a TV Using Antenna Connection.....	32-33	Specifications.....	38
Playback on a TV Using <i>AUDIO/VIDEO IN</i> Jacks.....	34-35	Sports Mode.....	27
Playback, First	10-11	Status Displays.....	24
Playback, Viewfinder.....	31	Still (II) Button	12,31,33,35
Positioning the Tape	21	<i>STILL</i> Button	14-15,31,33,35
<i>POWER CAM/OFF/PLAY</i> Switch.....	10-11,12	<i>STOP</i> Button.....	11,12,14-15,21,31,33,35
Power Zooming.....	25	<i>STOP</i> Display.....	24
Powering the Camcorder	16-19	Storage	30
Preset Program Indicators	24,27	<i>T</i> (Telephoto) Zoom Button.....	25
Preset Program Modes	24,27	Table of Contents	Front Cover
Problem Solving	36-37	Tally Light	11,12,15,21
Product Registration	Inside Front Cover	<i>TAPE END</i> Indicator.....	24
Program Preset Modes	24,27	<i>TAPE</i> Indicator.....	24
Quick Review.....	21	Tape Copying	32-35
RCA Video Cassettes.....	20,30	Tape Positioning	21
<i>REC</i> Display.....	24	Things to Avoid	30
<i>REC START/STOP</i> Button (Thumb Trigger)...	11,13	Thumb Trigger.....	11,13
<i>RECORD START/STOP</i> Button.....	14-15	Tilt Adjustment, Viewfinder.....	23
Record-Protect (Safety) Tab	20	Time and Date Display	22-23
Recording Speed and Times	20	Time and Date, Recording	23
Recording Steps, First-Time.....	8-13	Time and Date, Setting	22-23
Recording Tips.....	29	Time Counter Display	24-25
Recording, First	10-11	Time Counter with Memory Stop Feature	28
Refreshing the Battery	17	Tips, Recording.....	29
Registration Card	Inside Front Cover	Tips, Traveling.....	29
Remote Control.....	14-15	Tripod, Using.....	7
Review, Quick.....	21	Trouble Checks.....	36-37
<i>REW</i> (Rewind) Button.....	11,12,14-15,21,31,33,35	Turning On the Camcorder	10
<i>REW</i> Display	24	Unpacking the Camcorder	8
Safeguards, Important.....	2-3	Video Cassettes.....	20,30
Safety (Record-Protect) Tab	20	Viewfinder.....	10-11,12,23,24-25,31
Safety Instructions for AC Adapter/Charger	Inside Front Cover	Viewfinder Displays	24-25
Safety Instructions	Inside Front Cover	Viewfinder Playback.....	31
Safety Precautions.....	1	Viewfinder, Cleaning.....	23
		<i>W</i> (Wide Angle) Zoom Button.....	25
		Warranty	39
		Zooming, Power.....	25



For your nearest home
entertainment Dealer
or Authorized Servicenter
call toll-free in the U.S.A.

1-800-336-1900

If you would like a copy of this manual in French, please follow the
instructions below:

Si un livret d'instructions en français n'est pas inclus avec votre appareil, vous
pouvez en obtenir un (indiquer le numéro de modèle, votre nom, et votre
adresse) en vous adressant à:

Thomson Électronique Grand Public du Canada
Service des données techniques
6540 Tomken Rd
Mississauga, Ontario, Canada L5T 2E9

Thomson Consumer Electronics
600 N Sherman Dr, PO Box 1976
Indianapolis, IN 46206

© 1992 Thomson Consumer Electronics, Inc.
Trademark(s)® Registered
Marca(s) Registrada(s)
Printed in Japan
Part Number 92-Pro807-1

